

**United States Department of the Interior
Heritage Conservation and Recreation Service**

**National Register of Historic Places
Inventory—Nomination Form**

See instructions in *How to Complete National Register Forms*
Type all entries—complete applicable sections

For HCRS use only

received **AUG 25 1982**

date entered

1. Name

historic Bates-Geers House

and/or common Geers House

2. Location E of Platoon

street & number Slabtown Road. not for publication

city, town Plato X vicinity of Roby congressional district #8 - Hon. Wendell Bailey

state Missouri code 29 county Texas code 215

3. Classification

Category	Ownership	Status	Present Use
<input type="checkbox"/> district	<input type="checkbox"/> public	<input type="checkbox"/> occupied	<input type="checkbox"/> agriculture
<input checked="" type="checkbox"/> building(s)	<input checked="" type="checkbox"/> private	<input checked="" type="checkbox"/> unoccupied	<input type="checkbox"/> commercial
<input type="checkbox"/> structure	<input type="checkbox"/> both	<input type="checkbox"/> work in progress	<input type="checkbox"/> educational
<input type="checkbox"/> site	Public Acquisition	Accessible	<input type="checkbox"/> entertainment
<input type="checkbox"/> object	<input type="checkbox"/> in process	<input checked="" type="checkbox"/> yes: restricted	<input type="checkbox"/> government
	<input type="checkbox"/> being considered	<input type="checkbox"/> yes: unrestricted	<input type="checkbox"/> industrial
	<input checked="" type="checkbox"/> N/A	<input type="checkbox"/> no	<input type="checkbox"/> military
			<input checked="" type="checkbox"/> other: vacant
			<input type="checkbox"/> museum
			<input type="checkbox"/> park
			<input type="checkbox"/> private residence
			<input type="checkbox"/> religious
			<input type="checkbox"/> scientific
			<input type="checkbox"/> transportation

4. Owner of Property

name 1. Mr. and Mrs. Harold Mayberry

street & number Palace Route

city, town Plato vicinity of state Missouri 65552

5. Location of Legal Description

courthouse, registry of deeds, etc. Office of Recorder of Deeds

street & number Texas County Courthouse

city, town Houston state Missouri

6. Representation in Existing Surveys

title Missouri State Historical Survey has this property been determined eligible? yes no

date 1980 federal state county local

depository for survey records Department of Natural Resources
Historic Preservation Program, P.O. Box 176

city, town Jefferson City state Missouri 65201

7. Description

Condition		Check one	Check one
<input type="checkbox"/> excellent	<input checked="" type="checkbox"/> deteriorated	<input type="checkbox"/> unaltered	<input checked="" type="checkbox"/> original site
<input type="checkbox"/> good	<input type="checkbox"/> ruins	<input checked="" type="checkbox"/> altered	<input type="checkbox"/> moved
<input type="checkbox"/> fair	<input type="checkbox"/> unexposed		date _____

Describe the present and original (if known) physical appearance

The Geers House, a prepossessing Greek Revival structure, looks west from a location amidst the Texas Hills of central Missouri. The frame house has solidly proportioned facades dominated by massive sandstone end chimneys. The two story, five bay main block has a single story el on the east.

Rising from a sandstone foundation, the house, sheathed with weatherboarding, presents Classical architectural detail: pediment-shaped window heads of 6-over-6 light windows and pilaster corner boards. A boxed cornice and frieze continue to form pediments on the secondary facades, where at each story, windows flank chimneys trimmed with stone courses at the level of shoulder and head. The three bay el has a fenestration pattern and sandstone chimney identical to that of the main block; its cornice and frieze are similar but end in returns on the east facade. The south facade of the el is faced by a built-in porch (now screened) supported by posts with pillow capitals.

Under the shelter of a pedimented porch with molded posts, the primary entrance creates the building's strongest statement. A singleleaf door with sidelights is crowned by a six light transom. Abutting door, sidelights and reveals are paneled pilasters, similar to the posts of the porch, which carry transom bar and door lintel. Details of the doorway were once painted red, white and blue.

Additions to the structure include a standing seam metal roof over the original wood shingles; a small porch over a secondary entrance on the north facade and a well house covering the original cistern at the rear of the house. A bay window added to the primary facade on the north and another cut on the south are intrusive and detract from the intended symmetry of the elevation.

Barring the installation of electricity the interior of the Geers House has survived in nearly original appearance. Each floor of the main block is comprised of two rooms and a central hallway. Woodwork in the house, varied but uniformly simple, is the expression of an early local craftsman. The north room of the first floor, lined with paneled wainscoting, presents a handcrafted paneled mantel. The room on the south, lined with wainscoting of a different design, has a similar mantelpiece. The walls of both rooms are plastered and have been wallpapered. The entrance hall, also wainscoted, has walls faced with vertical planking. Its primary decorative feature is the scored woodwork lining each doorway and the simple wooden banister of the stairway. The two upstairs rooms each have simple, heavy woodwork and mantels, and walls of vertical planking.

The interior of the one story addition has somewhat more sophisticated decorative details. A dining room, with two sets of doubleleaf, folding doors to the outside, passes from the north room. The "winter kitchen" to the rear has a mantel which, though paneled like those of the rest of the house, is accentuated by finer moldings and the ornamentation of small pilasters. All doors on the interior are original and some of their hardware is retained. Wide plank flooring remains throughout the house.

The Geers House lies on a low hill in the center of 285 acres of dormant farmland. About a mile of original split rail fencing still borders the property. Several out-buildings of later date are to the north and west of the house. Although some residential building is in progress in the area, the house remains the dominant force on the landscape. Structurally sound, but in need of restoration, the house will be returned to its original condition by the present owners.

**United States Department of the Interior
Heritage Conservation and Recreation Service**

**National Register of Historic Places
Inventory—Nomination Form**

GEERS HOUSE

For HCRS use only

received

date entered

Continuation sheet

Item number 4

Page 1

-
2. Mr. and Mrs. Douglas McCartha
3206 Anderson Drive
Lithia Springs, Georgia 30057
-

8. Significance

Period	Areas of Significance—Check and justify below			
<input type="checkbox"/> prehistoric	<input type="checkbox"/> archeology-prehistoric	<input type="checkbox"/> community planning	<input type="checkbox"/> landscape architecture	<input type="checkbox"/> religion
<input type="checkbox"/> 1400–1499	<input type="checkbox"/> archeology-historic	<input type="checkbox"/> conservation	<input type="checkbox"/> law	<input type="checkbox"/> science
<input type="checkbox"/> 1500–1599	<input type="checkbox"/> agriculture	<input type="checkbox"/> economics	<input type="checkbox"/> literature	<input type="checkbox"/> sculpture
<input type="checkbox"/> 1600–1699	<input checked="" type="checkbox"/> architecture	<input type="checkbox"/> education	<input type="checkbox"/> military	<input type="checkbox"/> social/ humanitarian
<input type="checkbox"/> 1700–1799	<input type="checkbox"/> art	<input type="checkbox"/> engineering	<input type="checkbox"/> music	<input type="checkbox"/> theater
<input checked="" type="checkbox"/> 1800–1899	<input type="checkbox"/> commerce	<input checked="" type="checkbox"/> exploration/settlement	<input type="checkbox"/> philosophy	<input type="checkbox"/> transportation
<input type="checkbox"/> 1900–	<input type="checkbox"/> communications	<input type="checkbox"/> industry	<input type="checkbox"/> politics/government	<input type="checkbox"/> other (specify)
		<input type="checkbox"/> invention		

Specific dates ca. 1840 **Builder/Architect** Unknown

Statement of Significance (in one paragraph)

The Geers House is a significant Greek Revival structure, a product of fine, early craftsmanship, created of local materials in a traditional vernacular vein. It is one of the few extant examples of early 19th century architecture in Texas County. Built by one of the area's earliest settlers, the Geers House has throughout its history been the home of leading Texas County families: a prime example of both pioneer workmanship and contemporary domestic architectural taste, it is important also because it is deeply intertwined with the history of the Texas County Hill Country.

Among the first settlers in the land that was to be Texas County was Addison Bates, who came from North Carolina in the 1830's and constructed a small sawmill on Paddy Creek. (The mill was still in existence as late as 1889). It was the first mill in the area and sent its finished lumber from the Texas forests as far away as Springfield, Missouri. Around 1840, Bates began the construction of the present house, an appropriate indicator of his thriving business and rising social status. Sandstone for the foundation was quarried on the property and pine trees from the hills around were sawn, planed and shaped at Bates' own mill. Labor, according to local history, was provided at least in part by slaves; remains of their cabins can still be seen far to the rear of the house. The house reflects a consistent trend in the transference into Missouri of eastern regional architectural types. Although such ornamental details as the monumental, trabeated entry, cornice and frieze appear in deference to the era's admiration for the nobility of the Greek Revival style, the house's 5 bay, central hall I-house form, its heavily proportioned elevations, with almost the massing of stone, and the large sandstone end chimneys which heighten the effect, have their origins in eastern vernacular tradition. Bates, like other emigrants from the east, built in the housing forms most familiar to him, thus indirectly ensuring their continuation in the west.

The house when completed was the showplace of the county. Sometime before the outset of the Civil War, Bates apparently sold the house to William and Mary Roby, whose family gave their name to the small village of Roby nearby. During their tenure, the house was reportedly used as a stagecoach stop and occasionally sheltered some invalid Union soldiers: according to local legend one such, known only as Abner, can sometimes be seen riding about the farm at night.

Towards the end of the war, the Union Army sent a platoon through the hills to suppress a band of Bushwhackers operating in the area. With them was John Geers, a young soldier from Illinois. Born March 20, 1841 in Madison County, he had enlisted in Company C, 117th Volunteer Infantry, in 1862. Geers was fascinated by the beautiful countryside with its plentiful game, and by the Bates place on 550 acres of land, which happened at the time to be for sale.

Returning to Texas County at the close of the war, Geers completed purchase of the house and land in 1872. His large family was raised on the property and in 1932, after his death, his youngest son Charles with his wife Rose, leased and later purchased the farm. While the land remained always in production, they supplimented their income during the 1940's by running a boarding house for workers employed in the construction of Fort Leonard Wood 17 miles to the north. The house continued in the Geers family until 1978, when it was purchased by the present owners, who intend to fully restore it.

9. Major Bibliographical References

1. Ellsberry, Eltz Prather, ed. "1860 Federal Census for Texas Co., Missouri." Mimeographed n.d.
2. Farmer, Frank "I Get Lonesome . . . When I Do I Pray" September 29, 1970

10. Geographical Data

Acreeage of nominated property 0.097 acres

Quadrangle name "Slabtown Spring, Mo."

Quadrangle scale 1:24,000

UMT References

A

1	5	5	7	8	4	8	0	4	1	5	15	8	18	10
Zone				Easting				Northing						

B

Zone				Easting				Northing						

C

Zone				Easting				Northing						

D

Zone				Easting				Northing						

E

Zone				Easting				Northing						

F

Zone				Easting				Northing						

G

Zone				Easting				Northing						

H

Zone				Easting				Northing						

Verbal boundary description and justification

The National Register boundary for the Bates-Geers House is contained within a north-south

List all states and counties for properties overlapping state or county boundaries

state	code	county	code

state	code	county	code

11. Form Prepared By

name/title 1. Janice R. Cameron, Research Assistant

organization Department of Natural Resources
Historic Preservation Program date October 7, 1980

street & number P.O. Box 176 telephone 314/751-4096

city or town Jefferson City state Missouri 65201

12. State Historic Preservation Officer Certification

The evaluated significance of this property within the state is:

national state local

As the designated State Historic Preservation Officer for the National Historic Preservation Act of 1966 (Public Law 89-665), I hereby nominate this property for inclusion in the National Register and certify that it has been evaluated according to the criteria and procedures set forth by the Heritage Conservation and Recreation Service.

State Historic Preservation Officer signature [Signature]

title Director, Department of Natural Resources date 8/17/80

For HCERS use only	
I hereby certify that this property is included in the National Register.	
<u>[Signature]</u> Keeper of the National Register	Entered in the National Register date <u>9/23/82</u>
Attest:	date
Chief of Registration	

**United States Department of the Interior
Heritage Conservation and Recreation Service**

**National Register of Historic Places
Inventory—Nomination Form**

GEERS HOUSE

For HCRS use only

received

date entered

Continuation sheet

Item number 9

Page 1

3. History of Texas County Missouri (Goodspeed Brothers Publishing Co., 1889)
4. Moser, Arthur Paul. "A Directory of Towns, Villages and Hamlets Past and Present of Texas County, Missouri". February 1974. Mimeographed.
5. NRINF prepared by Mrs. Joyce McCartha and Mrs. Janis Mayberry.

ITEM NUMBER 11

PAGE 1

2. Janis Mayberry and Joyce McCartha
Palace Route 417-458-4436
Plato, Missouri
3. James M. Denny, Section Chief, Nominations and Survey and State Contact Person
Department of Natural Resources October 1980
Historic Preservation Program 314:751-4096
P.O. Box 176
Jefferson City, Missouri 65102

ITEM NUMBER 10

PAGE 1

east-west oriented square 20 meters on each side, the center point being the above referenced UTM coordinate. This boundary recognizes that only the house and not its outbuildings or general settings is being proposed for nomination to the National Register of Historic Places.

FIRST FLOOR PLAN
GEERS HOUSE
PLATO, MISSOURI

NOT TO SCALE

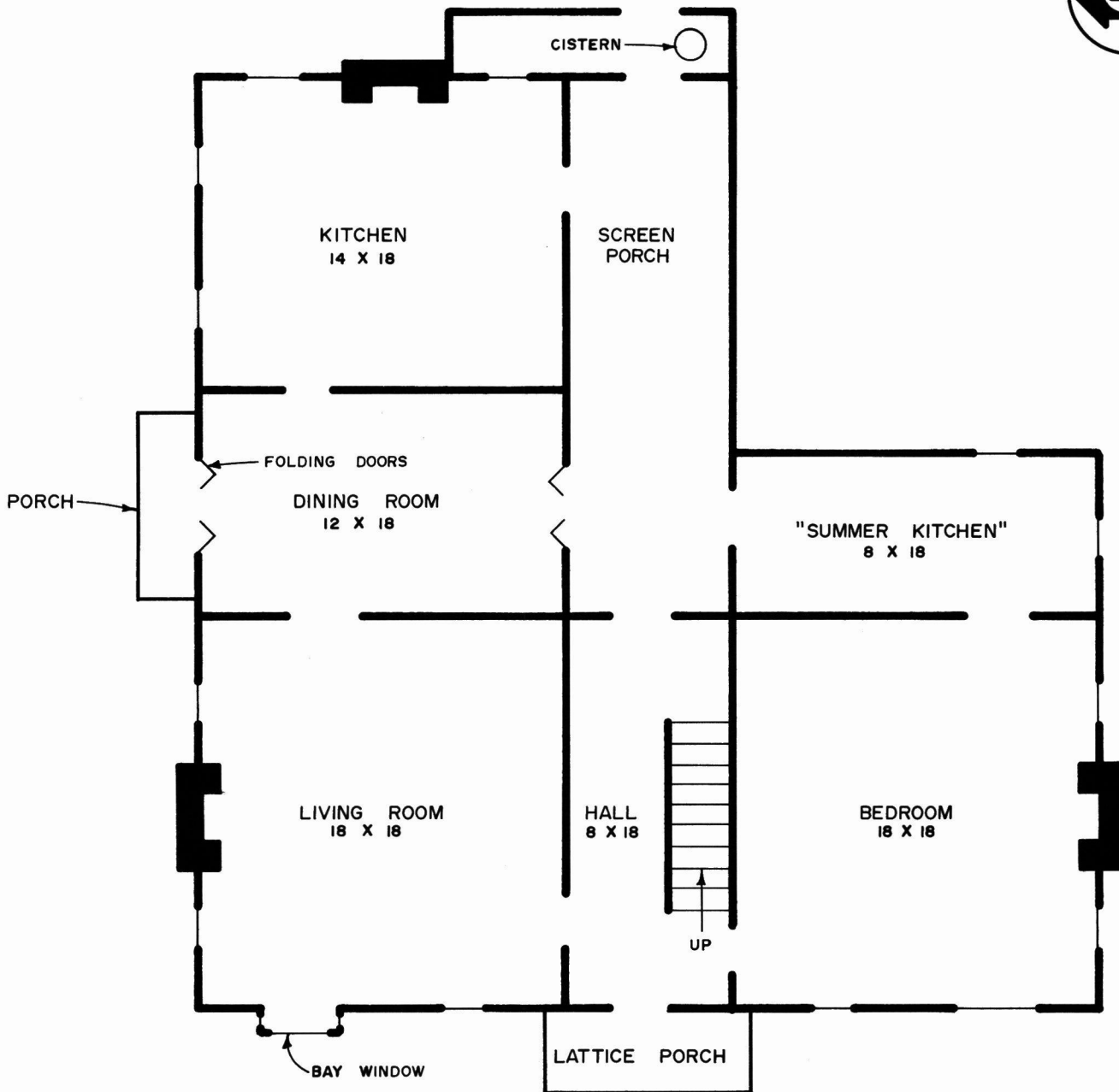

SECOND FLOOR PLAN
GEERS HOUSE
PLATO, MISSOURI

NOT TO SCALE

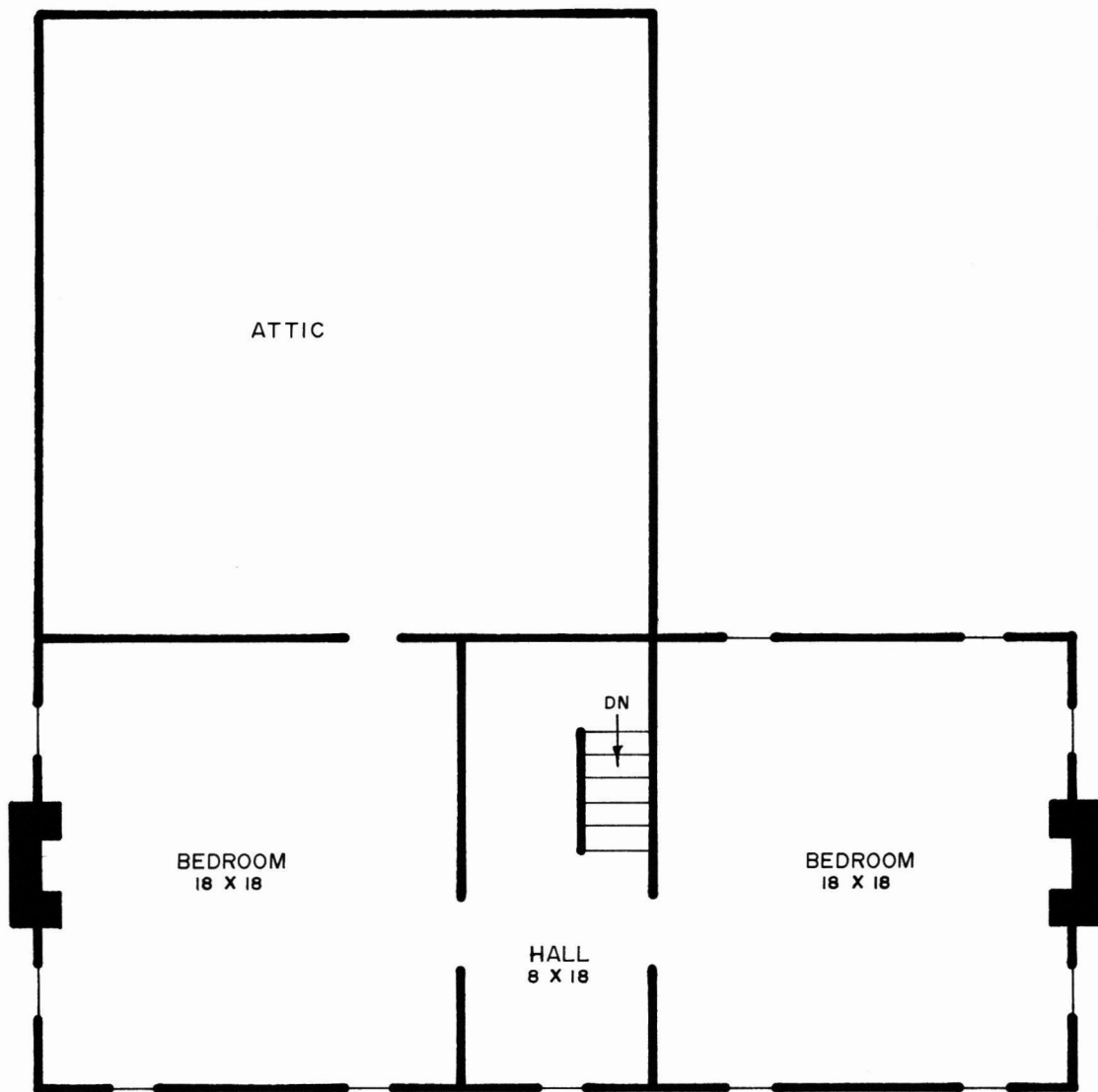

United States Department of the Interior
National Park Service

82003159

Bates-Geers House
Texas County
MISSOURI

Working No. 8/25/82-2327
Fed. Reg. Date: 2.1.83
Date Due: 9/23/82 - 10/9/82
Action: ACCEPT 9/23/82
Entered in the RETURN
National Register REJECT
Federal Agency: _____

- resubmission
- nomination by person or local government
- owner objection
- appeal

Substantive Review: sample request appeal NR decision

Reviewer's comments:

Recom./Criteria _____
Reviewer _____
Discipline _____
Date _____
 see continuation sheet

Nomination returned for: technical corrections cited below
 substantive reasons discussed below

1. Name

2. Location

3. Classification

Category	Ownership	Status	Present Use
	Public Acquisition	Accessible	

4. Owner of Property

5. Location of Legal Description

6. Representation in Existing Surveys

has this property been determined eligible? yes no

7. Description

Condition		Check one	Check one
<input type="checkbox"/> excellent	<input type="checkbox"/> deteriorated	<input type="checkbox"/> unaltered	<input type="checkbox"/> original site
<input type="checkbox"/> good	<input type="checkbox"/> ruins	<input type="checkbox"/> altered	<input type="checkbox"/> moved date _____
<input type="checkbox"/> fair	<input type="checkbox"/> unexposed		

Describe the present and original (if known) physical appearance

- summary paragraph
- completeness
- clarity
- alterations/integrity
- dates
- boundary selection

8. Significance

Period _____ Areas of Significance—Check and justify below

Specific dates _____ Builder/Architect _____

Statement of Significance (in one paragraph)

- _____ summary paragraph
- _____ completeness
- _____ clarity
- _____ applicable criteria
- _____ justification of areas checked
- _____ relating significance to the resource
- _____ context
- _____ relationship of integrity to significance
- _____ justification of exception
- _____ other

9. Major Bibliographical References

10. Geographical Data

Acres of nominated property _____

Quadrangle name _____

UMT References _____

Verbal boundary description and justification _____

11. Form Prepared By

12. State Historic Preservation Officer Certification

The evaluated significance of this property within the state is:

_____ national _____ state _____ local

State Historic Preservation Officer signature _____

title _____ date _____

13. Other

- _____ Maps
- _____ Photographs
- _____ Other

Questions concerning this nomination may be directed to _____

Signed _____ Date _____ Phone: 202 272-3504

Comments for any item may be continued on an attached sheet



GEERS HOUSE
Plato, Missouri

#1 of 7

Photographer: Janice R. Cameron
September 3, 1980

Neg. Loc.: Department of Natural Resources
P.O. Box 176
Jefferson City, MO 65102

General view of Primary Facade from the
west.



GEERS HOUSE
Plato, Missouri

#2 of 7

Photographer: Janice R. Cameron
September 3, 1980

Neg. Loc.: Department of Natural Resources
P.O. Box 176
Jefferson City, MO 65102

General view of south facade.



GEERS HOUSE
Plato, Missouri

#3 of 7

Photographer: Janice R. Cameron
September 3, 1980

Neg. Loc.: Department of Natural Resources
P.O. Box 176
Jefferson City, MO 65102

General view of north facade.



GEERS HOUSE
Plato, Missouri

#4 of 7

Photographer: Janice R. Cameron
September 3, 1980

Neg. Loc.: Department of Natural Resources
P.O. Box 176
Jefferson City, MO 65102

General view of east facade from the
southeast.



GEERS HOUSE
Plato, Missouri

#5 of 7

Photographer: Janice R. Cameron
September 3, 1980

Neg. Loc.: Department of Natural Resources
P.O. Box 176
Jefferson City, MO 65102

View of primary entrance from the west.

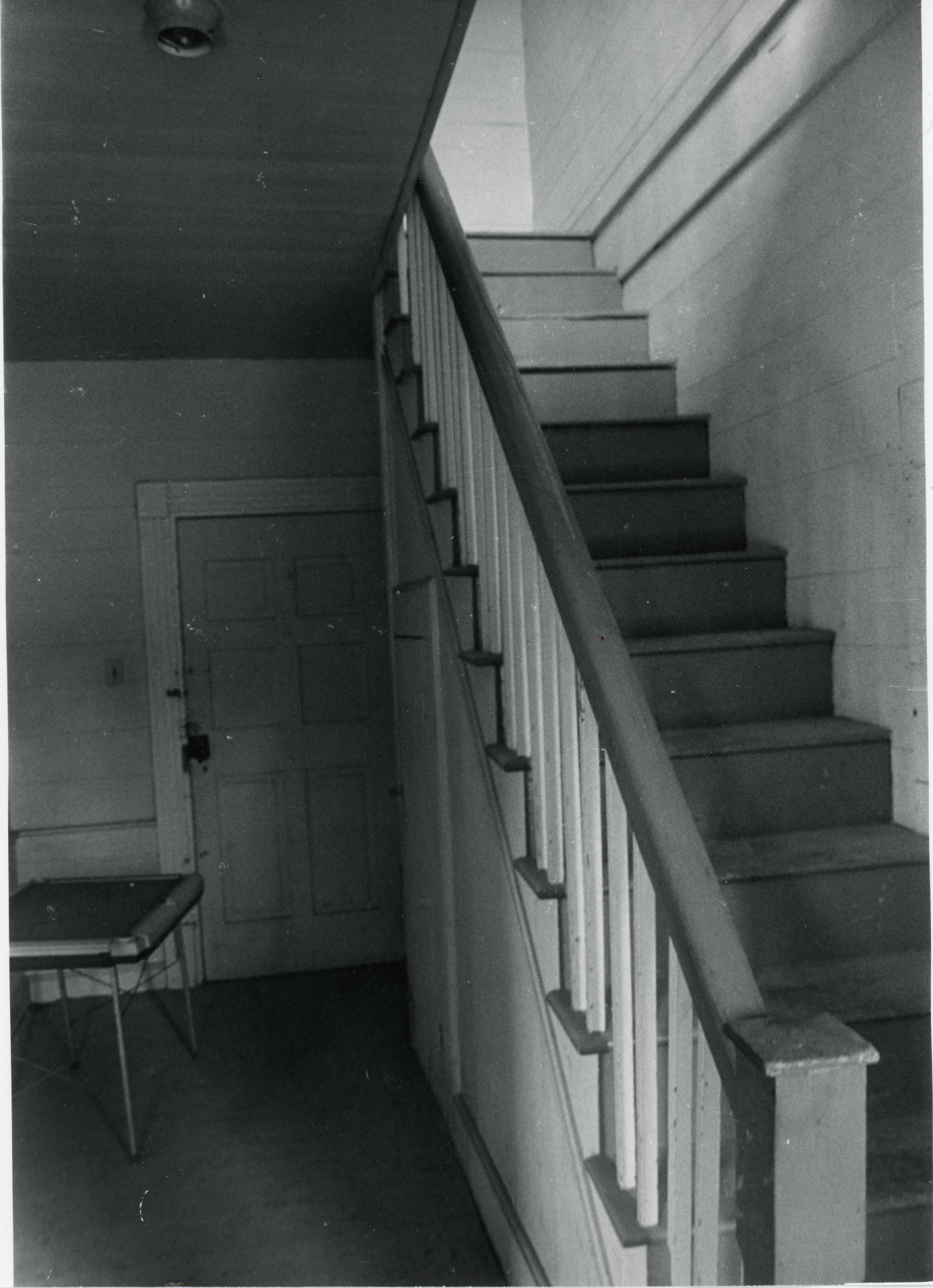

GEERS HOUSE
Plato, Missouri

#6 of 7

Photographer: Janice R. Cameron
September 3, 1980

Neg. Loc.: Department of Natural Resources
P.O. Box 176
Jefferson City, MO 65102

View of entrance hall showing stairway
banister and woodwork.



GEERS HOUSE
Plato, Missouri

#7 of 7

Photographer: Janice R. Cameron
September 3, 1980

Neg. Loc.: Department of Natural Resources
P.O. Box 176
Jefferson City, MO 65102

View of kitchen fireplace, looking towards
the east.

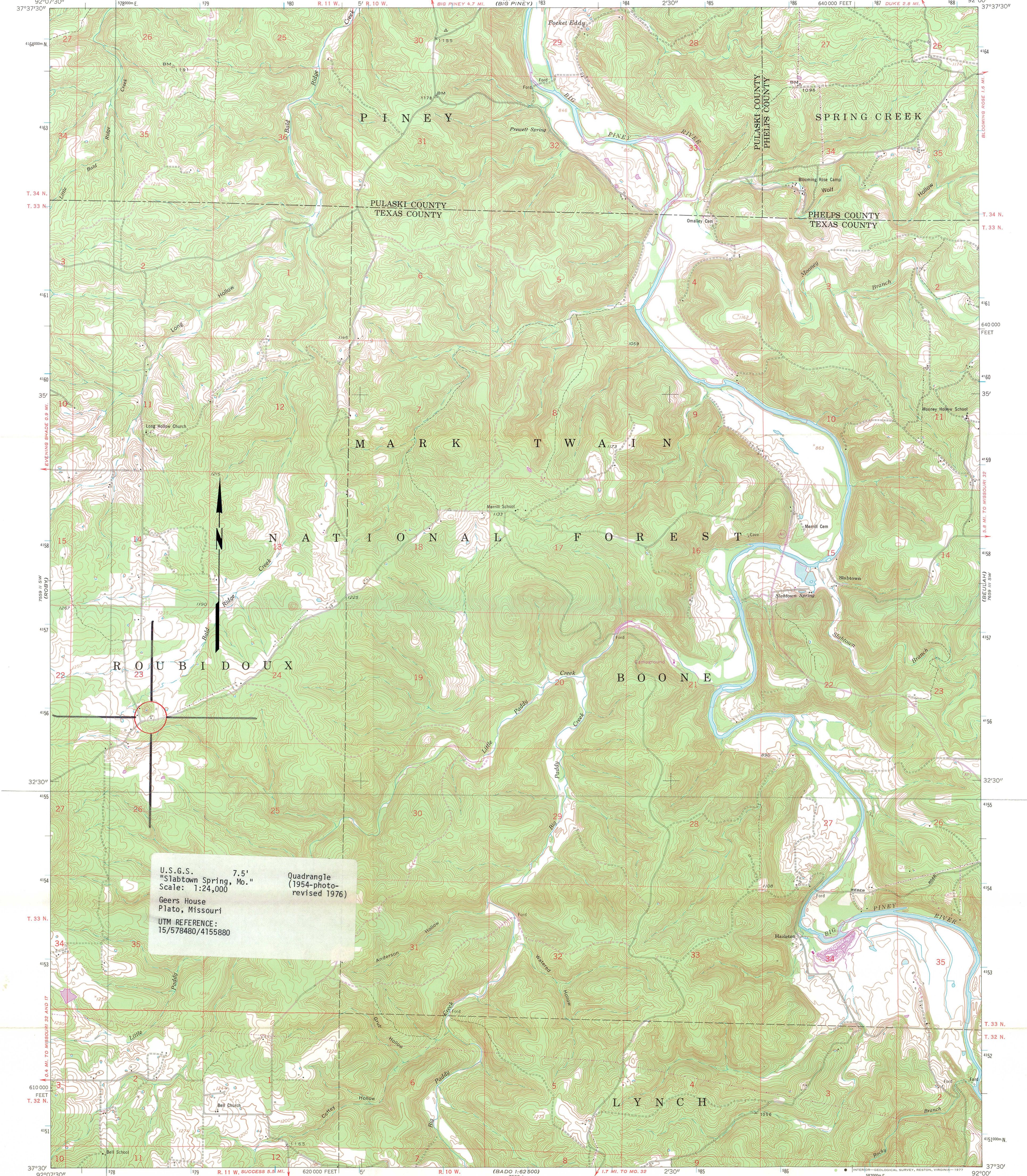

U.S.G.S. 7.5' "Slabtown Spring, Mo." Quadrangle (1954-photo-revised 1976)
 Geers House Plato, Missouri
 UTM REFERENCE: 15/578480/4155880

Mapped by the Army Map Service
 Published for civil use by the Geological Survey
 Control by USGS, USC&GS, and USCE
 Topography from aerial photographs by photogrammetric methods
 Aerial photographs taken 1953. Field check 1954
 Polyconic projection, 1927 North American datum
 10,000-foot grid based on Missouri coordinate system, central zone
 1000-meter Universal Transverse Mercator grid ticks, zone 15, shown in blue
 Unchecked elevations are shown in brown
 Revisions shown in purple compiled by the Geological Survey from aerial photographs taken 1976. This information not field checked

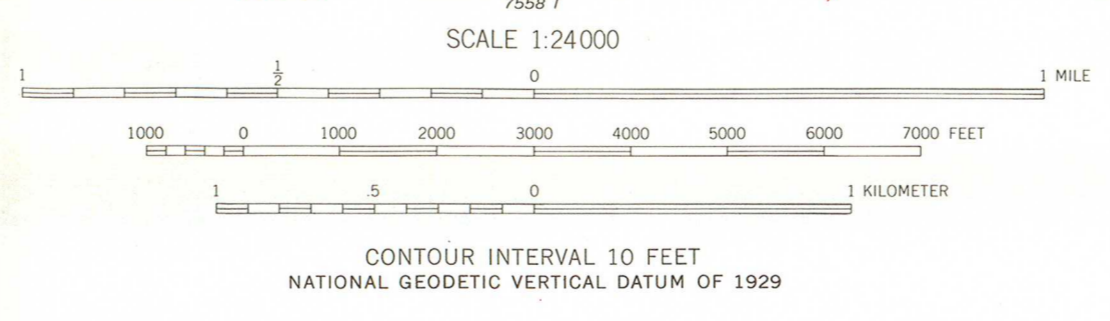
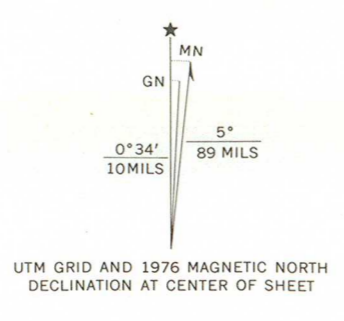

ROAD CLASSIFICATION
 Light-duty ————— Unimproved dirt =-----
 State Route ○
 SLABTOWN SPRING, MO.
 SE 1/4 BIG PINEY 15' QUADRANGLE
 N 3730—W 9200/7.5
 1954
 PHOTOREVISED 1976
 AMS 7559 II SE—SERIES V879

FOR SALE BY U.S. GEOLOGICAL SURVEY, DENVER, COLORADO 80225, OR RESTON, VIRGINIA 22092,
 AND THE DIVISION OF RESEARCH AND TECHNICAL INFORMATION
 MISSOURI DEPARTMENT OF NATURAL RESOURCES, ROLLA, MISSOURI 65401
 A FOLDER DESCRIBING TOPOGRAPHIC MAPS AND SYMBOLS IS AVAILABLE ON REQUEST

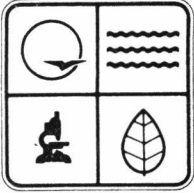

August 19, 1982

Mr. Jerry Rogers
Associate Director
National Park Service
18th & C Streets
Washington, D.C. 20240

Dear Jerry:

Enclosed please find the following submission from Missouri for nomination to the National Register of Historic Places:

- ✓ 1. BATES-GEERS HOUSE, Slabtown Road,
Plato, Texas County, Missouri
2. LEONARD, ABIEL HOUSE, 1 Leonard Avenue,
Fayette, Howard County, Missouri
3. ERMELING HOUSE, 205 South Duchesne Drive,
St. Charles, St. Charles County, Missouri
4. STARK-CARLSON HOUSE, 220 North 3rd Street,
Louisiana, Pike County, Missouri
5. WORTH COUNTY COURTHOUSE, Public Square,
Grant City, Worth County, Missouri
6. VOSTEEN-HAUCH HOUSE, 913 North Second Street,
St. Joseph, Buchanan County, Missouri
7. WILSON EPHRAIM J. FARM COMPLEX, Route 2,
Palmyra, Marion County, Missouri
8. HICKLIN HEARTHSTONE, RFD 2, Box 79,
Lexington, Lafayette County, Missouri
9. WEBSTER COLLEGE-EDEN THEOLOGICAL SEMINARY COLLEGIATE DISTRICT,
470 & 475 East Lockwood Avenue
Webster Groves, St. Louis County, Missouri
10. THOMSON, GENERAL DAVID, HOUSE, Route 1,
Hughesville, Pettis County, Missouri



MISSOURI DEPARTMENT OF NATURAL RESOURCES
P.O. Box 176 Jefferson City, Missouri 65102 (314) 751-2479

Christopher S. Bond Governor
Fred A. Lafser Director

Division of Parks and Historic Preservation
John Karel Director

Mr. Jerry Rogers

August 19, 1982

Page 2

These nominations were approved by our State Review Board, the Missouri Advisory Council on Historic Preservation, on June 25-26, 1982 and have been signed by Missouri's State Historic Preservation Officer, Fred A. Lafser. All owners and appropriate elected public officials were notified and provided forty-five (45) days to comment on the above proposed nominations in accordance with Section 60.6(c) 36CFR60, interim regulations, using the exact notification format recommended by the National Register. No objections, notarized or otherwise, were received for the above referenced nomination.

If there are any questions concerning these submissions, please contact James M. Denny of my staff at 314/751-4096.

Sincerely,

DIVISION OF PARKS AND HISTORIC PRESERVATION

A handwritten signature in black ink, appearing to read "Book" or "Bucker", written in a cursive style.

B.H. Rucker
Assistant Director

BHR:jdk

Enclosure: as stated