



**United States Department of the Interior  
National Park Service**

**National Register of Historic Places  
Registration Form**

10  
Result

**1. Name of Property**

historic name The Plaza Hotel

other names/site number n/a

**2. Location**

street & number 715 Main Street [n/a] not for publication

city or town Trenton [n/a] vicinity

state Missouri code MO county Grundy code 079 zip code 64683

**3. State/Federal Agency Certification**

As the designated authority under the National Historic Preservation Act, as amended, I hereby certify that this  nomination  request for determination of eligibility meets the documentation standards for registering properties in the National Register of Historic Places and meets the procedural and professional requirements set forth in 36 CFR Part 60. In my opinion, the property  meets  does not meet the National Register criteria. I recommend that this property be considered significant  nationally  statewide  locally.  
( See continuation sheet for additional comments [ ]. )

*Claire F. Blackwell*

*6 Dec. 00*

Signature of certifying official/Title Claire F. Blackwell/Deputy SHPO

Date

Missouri Department of Natural Resources  
State or Federal agency and bureau

In my opinion, the property  meets  does not meet the National Register criteria.  
( See continuation sheet for additional comments [ ]. )

Signature of certifying official/Title \_\_\_\_\_

State or Federal agency and bureau \_\_\_\_\_

**4. National Park Service Certification**

I hereby certify that the property is:

- entered in the National Register  
See continuation sheet [ ].
- determined eligible for the  
National Register  
See continuation sheet [ ].
- determined not eligible for the  
National Register.
- removed from the  
National Register
- other, explain  
See continuation sheet [ ].

Signature of the Keeper

*Beth Board*

Date

*7/18/01*

Name of Property

5. Classification

Ownership of Property  
(Check as many boxes as apply)

- private
- public-local
- public-State
- public-Federal

Category of Property  
(Check only one box)

- building(s)
- district
- site
- structure
- object

Number of Resources within Property  
(Do not include previously listed resources in the count.)

Contributing	Noncontributing	
1	0	buildings
0	0	sites
0	0	structures
0	0	objects
1	0	Total

Name of related multiple property listing  
(Enter "N/A" if property is not part of a multiple property listing.)

N/A

Number of contributing resources previously listed  
in the National Register

N/A

6. Function or Use

Historic Functions  
(Enter categories from instructions)

DOMESTIC: hotel  
RECREATION AND CULTURE: theater

Current Functions  
(Enter categories from instructions)

VACANT

7. Description

Architectural Classification  
(Enter categories from instructions)

MODERN MOVEMENT: Art Deco

Materials  
(Enter categories from instructions)

foundation concrete  
walls concrete  
roof synthetics  
other

Narrative Description

(Describe the historic and current condition of the property on one or more continuation sheets.)

NATIONAL REGISTER OF HISTORIC PLACES  
CONTINUATION SHEET  
Section number 7

Page 1

The Plaza Hotel  
Grundy County, Missouri

---

## SUMMARY

The Plaza Hotel, located at 715 Main Street, Trenton, Grundy County, Missouri, was designed by Kansas City, Missouri, architect Jens C. Pederson and constructed in 1929-1930. Measuring approximately 88 feet by 124 feet, the Plaza Hotel is a five-story reinforced concrete building planned by Pederson in the Art Deco style and features Nel-Stone™, a pre-cast, concrete block exterior, concrete roof and floors. The fireproof facility is sited in downtown Trenton, Missouri, across from the Grundy Country Courthouse reached by Missouri Highway 6. Late 19<sup>th</sup> and early 20<sup>th</sup> commercial buildings, designed mostly in the vernacular and constructed of brick, are adjacent to the Plaza Hotel.

## ELABORATION

The main façade of the Plaza Hotel faces east. The first story storefront level, slightly modified from the original, features multiple aluminum-framed entrances including a double door unit located at the hotel lobby (2<sup>nd</sup> bay moving north to south), paired double-doors at the theater lobby (4<sup>th</sup> bay), and a single door at both the 3<sup>rd</sup>, 6<sup>th</sup>, and 7<sup>th</sup> bays. Plate glass windows, with geometric patterned leaded glass transoms, have been boarded-up, but remain in good condition. Original Art Deco, triangularly-designed double-hung, sash fenestration with concrete sills of the main façade (paired at the end bays) is no longer extant; openings are exposed for window installation, design based on a salvaged unit. The storefront design of the main façade wraps to the north façade at the first two bays. Fenestration configuration of the main façade was originally repeated at the north façade; windows at this location were predominately placed in pairs. The north façade also features a secondary entrance (located between the 4<sup>th</sup> and 5<sup>th</sup> bays, moving east to west), and a tunnel leading to the south façade located at the 10<sup>th</sup> bay. The west façade of the Plaza Hotel, partially obscured by the adjacent one-story building, features minimal fenestration with one-over-one, double-hung, sash units. A fire escape is located at the 3<sup>rd</sup> bay (moving north to south).

The Plaza Hotel, originally rectangular in shape, housed a theater with barrel vaulted roof at the southern portion of the building. As originally designed, the south wall of the theater, beginning at the 3<sup>rd</sup> bay of the south façade, was generally devoid of any

United States Department of the Interior  
National Park Service

NATIONAL REGISTER OF HISTORIC PLACES  
CONTINUATION SHEET

The Plaza Hotel  
Grundy County, Missouri

Section number 7

Page 2

---

fenestration and/or embellishment. Rising only three stories, the upper stories of the south façade of the hotel proper, were exposed. Due to a recent fire, the theater portion of the Plaza Hotel, which remained in extremely deteriorated and hazardous condition, was razed, leaving the stage and a portion of its original west façade.

Additional exterior features of the Plaza Hotel include contrasting coved mortar joints, parapet wall with symmetrically-placed, geometric-shaped projections, a prominent elevator shaft at the north façade, and a centrally placed polygonal Art Deco marquee set below a neon sign with the word "PLAZA" that stretches to the base of the fourth story. The Art Deco flavor of this building is enhanced by the paired, painted vertical and horizontal concrete bands that accentuate the center and outer bays from the storefront level through the shaped parapets, and at the cornice line of the east façade. This linear accenting is continued at the north façade. Although the interior of the Plaza Hotel still displays original hotel rooms and corridors, much of the historic decoration is no longer extant. Descriptions of the hotel's interior décor were cited in various issues of the *Trenton Republican-Times*. The following is a compilation of these articles:

The lobby walls are painted pale green with rose trim. The drapes at the large windows are greyish tan monks cloth trimmed in black. A solid walnut cigar case and front desk on the west wall were built by Collier Adams Manufacturing Company of St. Joseph. Flooring is of varicolored composition board named Xite. The coffee shop, which seats 62 persons, is also floored with Xite, but of a different pattern. Transient rooms are located on the second through fourth floors. Some are furnished with twin beds, some with double beds each floor has rooms with tub or shower and each room has a large closet and a dressing room. Color schemes are two-tone green, tan and rose and blue and grey. Some rooms have connecting doors to serve families. Four room efficiency apartments are located on the fifth floor. A living room, dinette, kitchen, bath and bedroom are

United States Department of the Interior  
National Park Service

NATIONAL REGISTER OF HISTORIC PLACES  
CONTINUATION SHEET

The Plaza Hotel  
Grundy County, Missouri

Section number 7

Page 3

---

completely furnished. Five five-room efficiency apartments are located at the corners and ends of the transient floors.<sup>1</sup>

Today, the Plaza Hotel still maintains the general character of the exterior and interior of its original design, thereby conveying its use and significance as a first class hotel in Trenton, Missouri. Despite the loss of the theater portion to the rear of the building, the Plaza Hotel, including hotel lobby and reception area, corridors, elevator, stairs, and dining hall, remains intact. The intact unique exterior of Nel-Stone also speaks to the importance of this commercial property as a one-of-a-kind building for Trenton and the region.

#### **Plans for the Renovation of the Plaza Hotel**

The Plaza Hotel is currently undergoing a complete restoration. Plans for the historic tax credit project were prepared by Porter and Associates, Architects, Columbia, Missouri, in accordance with the *Secretary of the Interior's Standards* and have been approved by the National Park Service. The hotel portion, which originally contained 60 rooms, will feature 23 housing units for seniors. It is important to note that the theater, razed after a fire, will be partially rebuilt using salvaged original concrete blocks. The south wall of the theater, as well as the stage area, will be rebuilt and the original stylized murals of palm trees will be replicated. The theater will be *plein aire* and used as a community auditorium and playhouse. Additionally, the theater lobby area will be rebuilt.

---

<sup>1</sup> The *Trenton Republican Times*, various front-page articles dating from 1929-1930.

NPS Form 10-900-a  
(8-86)

United States Department of the Interior  
National Park Service

OMB Approval No. 1024-0018

NATIONAL REGISTER OF HISTORIC PLACES  
CONTINUATION SHEET

The Plaza Hotel  
Grundy County, Missouri

Section number 7

Page 4

---

The Plaza Hotel, 715 Main Street, Trenton, Missouri. No date published.

Source: *Time Was* 6 (Spring 1982), 38.



NATIONAL REGISTER OF HISTORIC PLACES  
CONTINUATION SHEET

The Plaza Hotel  
Grundy County, Missouri

Section number 7

Page 5

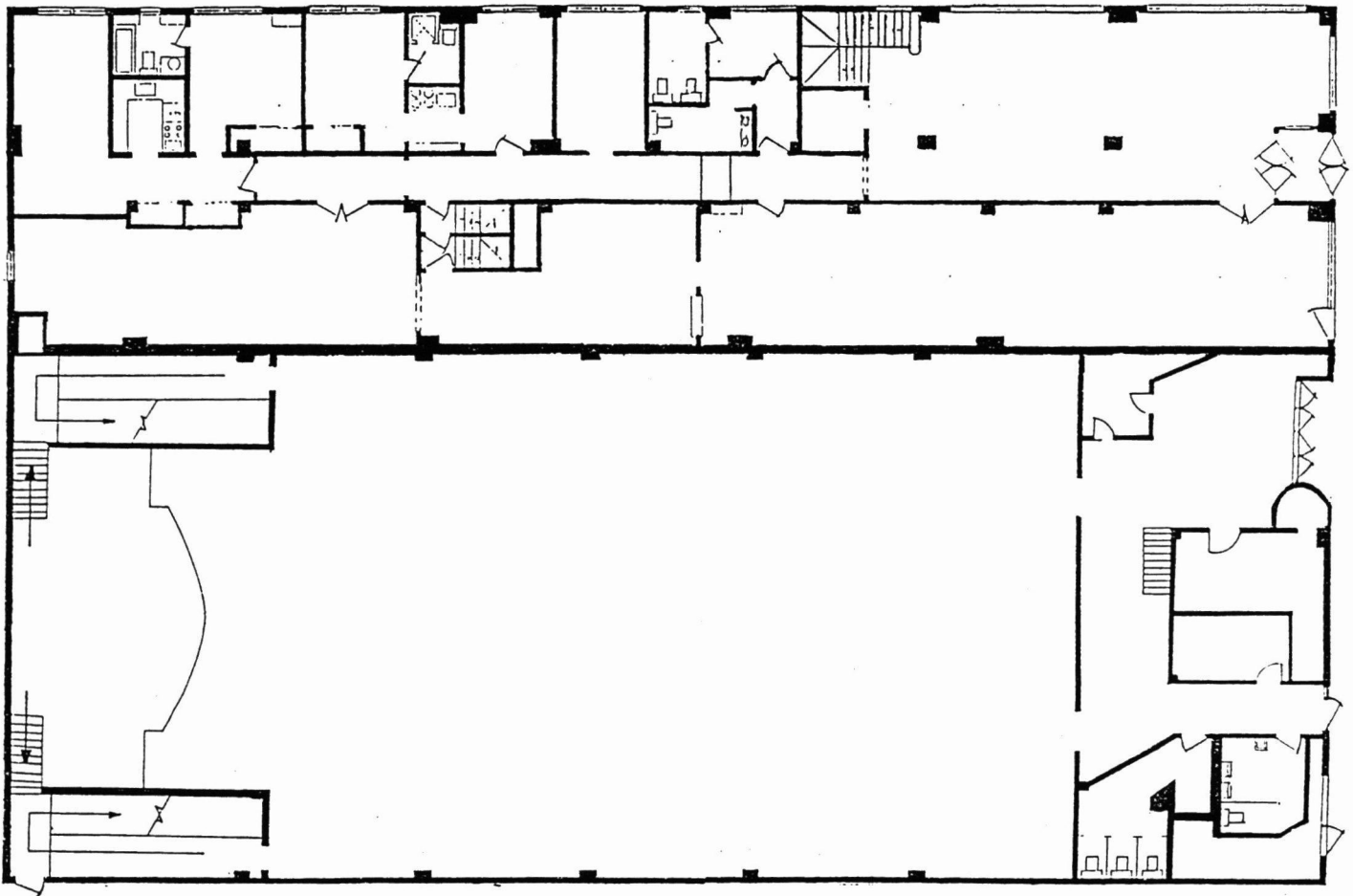

EXISTING FIRST FLOOR PLAN

SCALE: 1/16" = 1'-0"

7-29-99

PLAZA APARTMENTS - SENIOR HOUSING

715 MAIN STREET - TRENTON, MO

PORTER & ASSOCIATES - ARCHITECTS

COLUMBIA, MO - (573) 449-1835

**8. Statement of Significance**

**Applicable National Register Criteria**

(Mark "x" in one or more boxes for the criteria qualifying the property for National Register listing.)

- A** Property is associated with events that have made a significant contribution to the broad patterns of our history.
- B** Property is associated with the lives of persons significant in our past.
- C** Property embodies the distinctive characteristics of a type, period, or method of construction or represents the work of a master, or possesses high artistic values, or represents a significant and distinguishable entity whose components lack individual distinction.
- D** Property has yielded, or is likely to yield, information important in prehistory or history.

**Criteria Considerations**

(Mark "x" in all the boxes that apply.)

Property is:

- A** owned by a religious institution or used for religious purposes.
- B** removed from its original location.
- C** a birthplace or grave.
- D** a cemetery.
- E** a reconstructed building, object, or structure.
- F** a commemorative property.
- G** less than 50 years of age or achieved significance within the past 50 years.

**Narrative Statement of Significance**

(Explain the significance of the property on one or more continuation sheets.)

**9. Major Bibliographical References**

**Bibliography**

(Cite the books, articles, and other sources used in preparing this form on one or more continuation sheets.)

**Previous documentation on file (NPS):**

- preliminary determination of individual listing (36 CFR 67) has been requested
- previously listed in the National Register
- previously determined eligible by the National Register
- designated a National Historic Landmark
- recorded by Historic American Buildings Survey # \_\_\_\_\_
- recorded by Historic American Engineering Record # \_\_\_\_\_

**Areas of Significance**

(Enter categories from instructions)

COMMERCE  
ARCHITECTURE  
ENGINEERING

**Period of Significance**

1929-1950

**Significant Dates**

1929-1930

**Significant Person**

(Complete if Criterion B is marked above)

N/A

**Cultural Affiliation**

N/A

**Architect/Builder**

Pederson, Jens C., architect  
Hoffman, B. L., contractor

**Primary location of additional data:**

- State Historic Preservation Office
- Other State agency
- Federal agency
- Local government
- University
- Other

**Name of repository:**

Western Historic Manuscripts

(8-86)

United States Department of the Interior  
National Park Service

NATIONAL REGISTER OF HISTORIC PLACES  
CONTINUATION SHEET

The Plaza Hotel  
Grundy County, Missouri

**Section number 8****Page 6**

---

**SUMMARY**

The Plaza Hotel, located at 715 Main Street, Trenton, Grundy County, Missouri, is eligible for listing in the National Register of Historic Places under Criteria A and C and is significant in the following areas: **COMMERCE:** Constructed in 1929-1930, the Plaza Hotel was built for Kansas City entrepreneur Charles T. Sears and Harry F. Murphy. Construction of the hotel was spearheaded by the Trenton Commercial Club, the precursor to the Trenton Chamber of Commerce. Costing approximately \$300,000 to construct, the Plaza Hotel originally included a theater, ballroom beauty and barber shops, coffee shop and "air cooled" guest rooms. It was Trenton's first, "first class hotel" and became not only one of northern Missouri's best known apartment-hotels, but a gathering place for social and commercial leaders of the region as well. Additionally, the Plaza Hotel was often the center of political activity in this rural Missouri town.

**ARCHITECTURE and ENGINEERING:** Designed in the Art Deco style by Kansas City architect Jens C. Pederson, the Plaza Hotel is an unusual, rural example of this popular style of architecture and the only example of this architectural expression in Trenton. Furthermore, Nel-Stone, the pre-cast concrete blocks of the exterior measuring 12" x 12" x 6", not only serve as one of the key exterior elements of the building's vocabulary, but remain a unique 20<sup>th</sup> century structural peculiarity as well. Despite the loss of the theater portion, the Plaza Hotel retains sufficient elements of the original design to convey its significance. Its integrity of location, design, setting, materials, workmanship, feeling and association has been retained. The period of significance of the Plaza Hotel is 1930 to 1950, the end date determined by the arbitrary fifty-year cutoff for the National Register.

**ELABORATION****Trenton, Missouri, in 1929**

The City of Trenton is the county seat of Grundy County, Missouri. In 1929, the year construction began on the Plaza Hotel, Trenton's economy had not suffered the impact of the Depression as most of the urban areas of the country because it was a rail center for northern Missouri. As a thriving rural commercial center serving the

NATIONAL REGISTER OF HISTORIC PLACES  
CONTINUATION SHEET

The Plaza Hotel  
Grundy County, Missouri

Section number 8

Page 7

---

surrounding farming communities, Trenton was a division point for the Chicago, Rock Island and Pacific Railroad, The Chicago, Burlington and Quincy Railroad, as well as the Kansas City, Milwaukee and St. Paul Railroad. In 1929, a Rock Island project employed between five and six hundred men from Trenton and the vicinity.

Besides rail, access to Trenton was mostly by unpaved roads where travel by car was difficult. The State Highway Department began planning the first hard paved roads between Trenton and Kansas City, via Excelsior Springs and Smithville, in 1929.<sup>2</sup> It was November 1929 before U. S. Highway No. 65 was paved to the Iowa border. These highway projects not only created job opportunities for the local residents of Grundy County, but increased travel throughout northern Missouri as well. The anticipated need for quality hotel space became a major concern for the businessmen of Trenton who felt that a modern hotel facility was necessary for economic growth.

### **Trenton's Commercial Club and Funding for the Plaza Hotel**

Behind the scenes of many of the projects that were brought to Trenton during the Depression Era was the Commercial Club.<sup>3</sup> In 1928, the Commercial Club established a hotel committee to discuss the need for a first class, quality hotel that would serve as an enticement to traveling businessmen, increase Trenton's value as a commercial center in northern Missouri, and spur the tourist trade in the area as well.

The hotel committee of the Commercial Club consisted of local Trenton businessmen: Henry Heiman, Ott Stein, H. F. Hoffman, T. N. Witten, Don C. McVay, and was spearheaded by banker W. W. Alexander as chairman. For months prior to the announcement, the committee members secretly prepared to unveil plans for a first class hotel to be built within the city limits of Trenton. As rumors had been circulating about a new hotel, the committee decided to publicly announce their plans in the Saturday, June

---

<sup>2</sup> "Outlook for Trenton the best in Years," *Trenton (Missouri) Republican-Times* 25 June 1929, 1.

<sup>3</sup> The Commercial Club was the precursor to the present day Chamber of Commerce in Trenton.

NATIONAL REGISTER OF HISTORIC PLACES  
CONTINUATION SHEET

The Plaza Hotel  
Grundy County, Missouri

Section number 8

Page 8

---

15, 1929, edition of the *Trenton Republican-Times*. The bold faced headline appeared on the front page: "Construction To Start on \$300, 000.00 Hotel Here."

Committee members worked secretly in order to negotiate a fair price without burdening the city's financial position. After reviewing at a number of proposals from different investment and construction firms, the committee decided to accept a proposal submitted by a group of Kansas City entrepreneurs, represented by Charles T. Sears.<sup>4</sup> The committee's choice of the Sears group for the project was the result of a generous offer to begin building with only \$25,000 in subscribed bond money. All other offers had consisted of a minimum bond of \$200,000 to be guaranteed by the city. Many months of investigation went into the procedure before the offer by Sears was accepted. His proposal included plans for a modern theater that would occupy space within the hotel. This was a new concept, especially for a rural town, but the hotel committee accepted Sears' offer, which later was met with great enthusiasm from the public.<sup>5</sup>

On July 6 the *Trenton Republican-Times* reported that J. C. Pederson, Kansas City, Missouri, had been selected as the architect for the hotel project. B. L. Hoffman Construction Company, also of Kansas City, was awarded the contract for construction.<sup>6</sup> A week later an elevation of the proposed hotel appeared in the *Republican-Times* citing H. L. Jacobs of Kansas City as draftsman.<sup>7</sup> Little data is available concerning Pederson, Hoffman, or Jacobs. Entries into the *Hoye City Directory* for Kansas City between 1927 and 1930 indicate that these individuals were residing and employed in Kansas City, but additional biographical information has not surfaced at the time of this writing.<sup>8</sup>

---

<sup>4</sup> Sears was from Macon, Missouri, and graduated from the University of Missouri-Columbia, with a degree in law. Although he never practiced, he began a career in theater management and was the owner of Sears Outdoor Advertising Company, Chanute, Kansas.

<sup>5</sup> "Banquet in Basement to be Gala Affair at Trenton." *Trenton Republican-Times*, 10 May 1930, 1.

<sup>6</sup> It is not known if other architects and contractors were considered for the project.

<sup>7</sup> Various articles published in the *Trenton Republican-Times*, 1-12 July 1929.

<sup>8</sup> J. C. Pederson was listed in the Kansas City, Missouri, Hoye Directories for 1929 and 1930. In 1930 he was listed as Jens C. Pederson, architect, and wife Marie, 5208 Euclid Avenue. There is no record of Pederson in Kansas City after 1930. H. L. Jacobs, draftsman, was listed in the 1929 and 1930 Hoye Directories as Harry M. Jacobs, and wife Lillian. Jacobs was listed as a draftsman for Archer & Gloyd, Inc. a Kansas City architectural firm. B. L. Hoffman, the contractor for the construction of the Plaza Hotel, was

NATIONAL REGISTER OF HISTORIC PLACES  
CONTINUATION SHEET

The Plaza Hotel  
Grundy County, Missouri

Section number 8

Page 9

---

In just a little over a month, by July 19, more than half of the \$25,000 in stock for the hotel had been sold. Sears stipulated that no one subscription would exceed \$500.00 and stock would be offered in increments of \$50.00. Local individuals found the price affordable and began buying as little as one share each, making for a long list of stockholders. Sears had reserved the right to repurchase the local stock at any given time and the repurchase price of any public stock was guaranteed to include interest.<sup>9</sup>

The site chosen for the new hotel was the location of the three-story, brick Victorian styled Peery Hotel, which stood at the corner of Main and 8<sup>th</sup> streets, directly across from Grundy County Courthouse.<sup>10</sup> An architect's drawing of the new six-floor, modern and fireproof building appeared in the July 12, 1929, issue of the *Trenton Republican-Times* along with a detailed description:

The first three floors above the ground will be devoted to hotel rooms, about fifty percent of which will be equipped with baths. There will be fifteen rooms on a floor or seventy-five in the entire structure.

Above the rooms proper, the top floor of the building will be devoted to kitchen apartments; some double and some single ones, all equipped with baths. There will be sixteen of these...

The remainder of the ground floor space will be devoted to a large dining room, which will be located at the rear of the coffee shop. This room will be large and can be used for banquets and other things for which there is a need...

---

listed in the directories for 1929 and 1930 as B. L. Hoffman Construction Co., and wife Sadie. His business was listed at 1200 Oak St. and residence was listed as 5446 Drexel Way.

<sup>9</sup> "Hotel Stock More Than Half Sold." *Trenton Republican-Times*, 19 July 1929, 1. Sears remained financially involved in the hotel stock company until the sale of the Plaza Hotel to the Logsdon Hotel Company in 1969.

<sup>10</sup> "A Landmark Hotel Will Be Torn Down." *Trenton Republican-Times*, 23 July 1929, 1. The Peery House, later called the Trenton Hotel, stood at the corner of Main and 8<sup>th</sup> Street for 44 years. Constructed in 1885, the hotel was named in honor of Judge Stephen Peery,

NATIONAL REGISTER OF HISTORIC PLACES  
CONTINUATION SHEET

The Plaza Hotel  
Grundy County, Missouri

Section number 8

Page 10

---

The hotel will be equipped with both passenger and freight elevators....<sup>11</sup>

The *Republican-Times* also noted various rooms on the ground floor that were to be used for traveling salesmen needing "sample areas" and a writing room for guests equipped with long distance telephones for use by hotel clients, as well as the general public. Copies of the drawing were displayed in the front windows of the W.E. Pennell Jewelry Store and Stein's Store, both prominent businesses located in Trenton.

### Construction of the Plaza Hotel

Possession of the site for demolition was finalized on July 16, 1929. Machinery was brought in from Columbia, Missouri, to begin work on the razing of the old hotel upon its closing on July 21, 1929.<sup>12</sup> Finally, dreams of a first class hotel for Trenton became a reality. The first brick from the old hotel was removed ceremoniously on July 24, 1929. A front-page newspaper article gave a full account of the activities. In attendance were the members of the Hotel Committee, Sears, B.L. Hoffman, and Carrie Rogers Clark, owner of the *Trenton Republican-Times*. Mrs. Clark removed the first brick as the crowd sang "Auld Lang Syne." Sears, Hoffman, and, M. Taylor, Hoffman's engineering foreman, addressed the crowd and expressed their enthusiasm to build a new hotel for the community of Trenton. Clark made the final address as she removed the first brick. Refreshments were served as a finale to the festivities.

The hotel was of primary interest from the time of its inception, through the construction phase, and to its opening in May 1930. Over thirty-seven front-page articles covering the activities appeared in the *Trenton Republican-Times* between July 15, 1929, and May 14, 1930. While most articles announced the different floor phases and work progress, other articles discussed a plan by the Commercial Club to cover Trenton's hotel shortage and encouraged citizens living in close proximity to the downtown area to lease

---

<sup>11</sup> "Possession of Trenton Hotel Asked." *Trenton Republican-Times*, 12 July 1929, 1.

<sup>12</sup> Compiled from various articles. *Trenton Republican-Times*, 16-20 July 1929.

NATIONAL REGISTER OF HISTORIC PLACES  
CONTINUATION SHEET

The Plaza Hotel  
Grundy County, Missouri

Section number 8

Page 11

---

any spare rooms in their residences as construction on the new hotel continued.<sup>13</sup>

Other newspaper accounts gave brief glimpses of the importance of the hotel to the community. In addition, Sears, having purchased the old hotel in its entirety, including its furnishings, donated the shoe shine stand and its equipment to Trenton students to use in fund-raising. He also offered high school seniors after-school jobs clearing off rubble during the razing of the old Trenton Hotel.

Chronicles of the hotel's construction were ultimately of greatest importance and the majority of articles written about the Plaza Hotel were progress reports to the community. The *Republican-Times*, October 25, 1929, confirmed that concrete was being used throughout the structure, including stairs and the theater's stage. All conduit work was set in place prior to pouring the concrete. An excerpt from the *Republican-Times* expressed the durability of the construction:

Each part of the structure is connected solidly with concrete and steel into a single piece of material, and it will be an exceedingly difficult matter to tear out the building if it is ever necessary, Mr. Sears pointed out.<sup>14</sup>

By November 18, the ceiling had been poured for the roof of the theater. With its completion, the job of interior work could continue regardless of weather conditions. Sears had anticipated an early opening of the theater scheduled for January 1, 1930. The boiler for the heating plant had arrived and was being installed, all lighting and fixtures had been ordered and a master radio, giving access to radio from a speaker wired to the lighting fixtures in the ceiling of each hotel room, was also on order. The installation of the boiler and heating system allowed work to progress on the interior. By December 20, 1929, it was announced that the gala opening would move to Christmas Day, but this event was further delayed.

---

<sup>13</sup> "People Asked to List Spare Rooms." *Trenton Republican-Times*, 24 July 1929, 1.

<sup>14</sup> "Hotel Third Done Says Mr. Sears Today." *Trenton Republican-Times*, 25 October 1929, 1.

NATIONAL REGISTER OF HISTORIC PLACES  
CONTINUATION SHEET

The Plaza Hotel  
Grundy County, Missouri

Section number 8

Page 12

---

Construction continued through the winter months. Interior partitions had been completed on the first two floors and plastering was to begin by January 16. On March 10, it was reported that the hotel would be ready for opening around May 1. In the basement, plumbers were working on the area to be used as a large ballroom and dining area just below the theater.

On April 12, 1930, local electricians under the direction of E. R. Holloway hung the exterior neon sign. As described in the *Republican-Times*, the 15' 6" x 4' red neon sign featured lettering in a modified Gothic style. The grand opening of the hotel, eventhough unscheduled to date, was already fully booked with reservations received from "theatrical and moving picture friends of Mr. Sears."<sup>15</sup> By April 30, the carpeting had been laid and installation of Murphy-hide-a-beds was in progress. The apartment kitchenettes of the fourth and fifth floors were fitted with Catoranettes, a combination stove, refrigerator and cupboard also made by the Murphy Company.<sup>16</sup> As the work on the interior progressed, the exterior was near completion when workers dismantled the hoist used in transporting building material to the roof. Workmen were pointing the exterior of the building using red-tinted mortar, and the windows were being trimmed in green.

"Hotel Plaza Opening Will Be On May 13" was among the front-page headlines on May 6, 1930. Banquet tickets went on sale for \$2.50 a plate. The price included a pre-showing of the "The Jazz Singer" starring Al Jolson. As anticipated, the celebration was a major event in Trenton and although the original plan was to entertain no more than two hundred and fifty people, the crowd swelled to over four hundred. The local high school's Home Economics class served the meal and local bands and singers provided musical entertainment. Speakers at the event consisted of ministers representing area churches, the mayor, members of the Commercial Club, and Charles T. Sears. The newspaper printed numerous ads of congratulations on the opening of the hotel from several

---

<sup>15</sup> "New Plaza Sign is Being Hung Today." *Trenton Republican-Times*, 12 April 1930, 1.

<sup>16</sup> "Catoranettes are Combination Units of Stove Refrigerator and Cupboard." *Trenton Republican-Times*, 30 April 1930, 1.

NATIONAL REGISTER OF HISTORIC PLACES  
CONTINUATION SHEET

The Plaza Hotel  
Grundy County, Missouri

Section number 8

Page 13

---

businesses located throughout Trenton and Kansas City.

From its inception, it is undeniable that the Plaza Hotel became a symbol of progress and growth for the rural farming community of northern Missouri. One observation that was made during the opening ceremonies came from Judge A. G. Knight. He admitted to having the opinion early in the construction phase that the “building would not stand... [I] waited in vain for the building to crumble... Finally erected, of concrete and steel, [I] now believe a cyclone might roll in along the street but there would be no damage done to speak of to the structure.”<sup>17</sup> Knight’s opening night statement alludes to the unusual use of concrete and steel in a building designed for a small rural community. Not only was the Art Deco design all but rare in northern Missouri, but the particular technique used in the construction of the Trenton Plaza Hotel was unfamiliar.

Throughout the years, the Plaza Hotel catered to a number of locals and travelers alike including judges and state government staff. From the time of its opening in 1930 to its closing in 1980, the Plaza Hotel remained the only first-class hotel in downtown Trenton. Today, plans to rehabilitate the hotel are now in progress. Porter and Associates, Columbia, Missouri, have prepared construction drawings for the rehab. Plans for Trenton’s Plaza Hotel, conducted in accordance with *The Secretary of the Interior’s Standards*, has been approved by the National Park Service.

### **The Plaza Hotel’s Unique Construction and Design**

Generally speaking, there is a wealth of information on the use of concrete in both trade publications and technical sources from the 1920s, yet journal articles about Nel-Stone, the pre-cast concrete block manufactured by the Nel Stone Company, Carthage, Missouri, and used at the Plaza Hotel, has not been found.<sup>18</sup> Nevertheless, it appears that the Plaza Hotel represents a unique building technique and material, especially for a rural

---

<sup>17</sup> “Grand Opening of Hotel Plaza Was Gala Affair.” *Trenton Republican–Times*, 14 May 1930, 3.

<sup>18</sup> *Mid-West Contractor*, October 16, 1929, 32. The Nelstone Company, Carthage, Missouri, was registered with the Secretary of State of Missouri as a fictitious name on July 22, 1929 (No. X00005060). It was also registered to E. S. Rhoades, 1724 Wabash, Kansas City, Missouri.

NATIONAL REGISTER OF HISTORIC PLACES  
CONTINUATION SHEET

The Plaza Hotel  
Grundy County, Missouri

Section number 8

Page 14

---

community in 1929. It is known that William E. Nelson, Fort Worth, Texas, was granted a patent on March 30, 1920, for a "molding apparatus for producing concrete block or the like which are adapted to be assembled and formed into a monolithic structure."<sup>19</sup> The invention was to provide an apparatus adjustable for forming blocks of different sizes. The flanges of the mold provided recesses formed around the four edges of the molded block. These recesses received the concrete, which when the blocks were assembled, converted the same into a monolithic structure.<sup>20</sup>

Subsequent to his invention, Nelson registered a trademark in 1921 for the finished product of his molding apparatus. The trademark number 142,638 was for concrete building blocks, in Class No. 12, construction materials, called Nel-Stone. Nelson had been using the trademark continuously since February 1, 1920.<sup>21</sup> The Nel Stone Company in Carthage, Missouri, may have purchased the rights from Nelson to manufacture the concrete building blocks.

Tom Porter, the architect for the renovation of the Plaza Hotel, briefly described the concrete block and method of construction as follows:

The blocks [measure] 12" x 12" x 6". The exterior face [is] exposed concrete...the back is probably rough so that plaster [could] adhere. There are reveals for the mortar joint at all sides of the block. The blocks are very uniform in shape and apparently placed tightly together and grouted with cement [mix]. There are two reinforcing steel bars vertical in all vertical joints and one rebar horizontal in all bed joints.

---

<sup>19</sup> William R. Nelson, "Molding Apparatus." Patent No. 1,335,254. March 30, 1920. United States Patent Office, Washington, D.C.

<sup>20</sup> *Ibid.*

<sup>21</sup> William R. Nelson, "Trademark for concrete Building-Blocks." Trademark No. 142,638. May 17, 1921. United States Patent Office, Washington, D.C.

NATIONAL REGISTER OF HISTORIC PLACES  
CONTINUATION SHEET

The Plaza Hotel  
Grundy County, Missouri

Section number 8

Page 15

---

[It appears that] two blocks were set two at a time and then grouted into place. There was no apparent framing lumber.<sup>22</sup>

Pre-cast concrete blocks, such as the ones used at the Plaza Hotel, were not under regulation by the American Concrete Institute (ACI) until the 1930s. Before that period, blocks were, for the most part, manufactured locally under the designs of the particular manufacturing plant. Although the *Republican-Times* did an excellent job reporting on the interior décor of the hotel, accounts of exterior construction were left to the imagination from a few published photographs. In order to understand the Plaza Hotel's unique construction, it is necessary to closely examine one of the concrete blocks (as described above) and compare it to examples of similar building materials as discussed in contemporary sources.

A comparable type of concrete block used during the 1920s was a new product manufactured in New York called "Eyblock," the trade name of a wet cast concrete block that "produce[d] a wall that is absolutely dry, fireproof, heat insulating, of super strength, permanently beautiful, low in first cost, and with no maintenance cost."<sup>23</sup> In comparing "Eyblock" to the sketch of the block that was used in the construction of the Plaza Hotel, it is evident that the idea was not only a good one but one that could be embellished and streamlined. In contrast to the Plaza Hotel's 12" block, "Eyblock," is not as characteristically refined or elegant.

In 1929, Omaha, Nebraska, was the site of one of the largest concrete stone companies in the Midwest, that of Omaha Concrete Stone Company. The main product line was "Keystone" brand concrete and cinder blocks. Although the article did not indicate the range of the products or if the company produced a block similar to that used in the construction of the Plaza Hotel, it did state that they were a large operation that may have carried many types of pre-cast concrete block products.

---

<sup>22</sup> Letter from Tom Porter to C. Millstein, September 9, 00.

<sup>23</sup> Victor Ey, "Distinctive Block Made With Own Design of Equipment." *Concrete* 32 (February 1928), 35.

NATIONAL REGISTER OF HISTORIC PLACES  
CONTINUATION SHEET

The Plaza Hotel  
Grundy County, Missouri

Section number 8

Page 16

---

In Kansas City there is an example of a building that is strikingly similar in design and use of materials to Plaza Hotel. The Fourteenth and Baltimore Garage, designed in the Art Deco style by Kansas City architects McKecknie & Trask, and constructed in 1929, displays the same type and size of pre-cast concrete block used in the Plaza Hotel. Although no detailed information about the actual construction of the garage has been found, it was reported that Nelstone was used as a facing stone on the exterior.<sup>24</sup> Yet unlike the Plaza Hotel, Nelstone may not have been used as a structural material and the blocks vary in overall size and shape.

Outside the United States, the use of pre-cast concrete block as a building material was very popular. Most concrete principles published between 1910 and 1955 were based on British Standards. The concrete block manufacturing process was mechanized where molds were constructed of steel frames. These frames were sturdy and could be reused to produce various shapes and sizes. The larger concrete plants had drying yards and heated equipment that allowed the production of concrete blocks year round. Two methods were used: a dry cast method, which required a minimum amount of water to work the concrete into the steel molds, and a wet cast method that required a substantial amount of water to pour the mix into the mold. It appears that the poured method could produce the kind of cast block found in Trenton. The poured molds used were inexpensive, interchangeable to allow for size and density changes, and could hold the maximum number of blocks with a minimum number of parts.<sup>25</sup>

The "Winget" method of concrete house construction also displays similar characteristics to the concrete blocks of the Plaza Hotel. The process is much like laying brick but the walls can be layered several at a time, then back-grouted. Nails are used to join members of one block to the next. This method was found to be an easy, yet strong and durable method, for building homes throughout England.<sup>26</sup>

---

<sup>24</sup> See *Mid-West Contractor*, August 7, 1929, 30. The Nel Stone Company, Carthage, Missouri, was listed in this entry.

<sup>25</sup> Ey, *Concrete*, 36.

<sup>26</sup> "Concrete Housing in England." *Concrete* 31 (August 1927), 28.

NATIONAL REGISTER OF HISTORIC PLACES  
CONTINUATION SHEET

The Plaza Hotel  
Grundy County, Missouri

Section number 8

Page 17

---

A technique similar to the “Winget” method was used at the Plaza Hotel. As seen in a photo from the *Trenton Republican-Times*, the contractor did not use any scaffolding during construction. Only a tower was employed to convey materials. A sketch of the cast block of the Plaza Hotel may confirm that as the block was put in place, rebar was inserted into the channels, just as nails were used in the “Winget” method. After the rebar was fixed, grout material consisting of fine cement was poured into the channels to form the exterior walls. The floor treatment is unknown but it can be assumed that once the wall reached a full story height, the floor was poured as the building rose to its five-story height. Working with blocks rather than forms for wet poured concrete allowed work to continue in cold weather.

As stated earlier, the use of pre-cast concrete block, or concrete for that matter, was not a form of construction that was common in rural America in the 1920s and 30s. Concrete was a building medium used in major cities and most of the innovative construction methods in the use of concrete were used in Europe and England during this period. Few American architects with the exception of Frank Lloyd Wright and several based on the East and West Coast, used concrete as a form of architectural expression.<sup>27</sup>

In addition to its use of a unique construction material, the Plaza Hotel remains a rather rare example of Art Deco in northern Missouri. Three neighboring county courthouses, including those in Milan (Sullivan County, 1939), Bethany (Harrison County, 1939), and Maysville (DeKalb County, 1940) are all designed in the Art Deco. The Benbolt Theater, a 1949 landmark styled in the Art Deco, located in Chillicothe, was demolished. Only the DeKalb County Courthouse is listed in the National Register of Historic Places (1998).

---

<sup>27</sup>Examples of notable buildings from the 1920s displaying various types of concrete block exteriors include The Mayan Theater, Los Angeles (Morgan, Walls, and Clements, architects), The Maillard and Freeman Residences (Frank Lloyd Wright), and Notre Dame du Raincy (Auguste Perret, architect). According to Carl Condit, “concrete block has enjoyed a continuous use since the beginnings of concrete construction. Today, it is again popular as an imitation of stone masonry rough-faced, with the appropriate pigments to match the colors of natural stone.” See Condit, Carl. *American Building Art: The Twentieth Century*. New York: Oxford University Press, 1961, 353.

W. E. NELSON.  
MOLDING APPARATUS.  
APPLICATION FILED MAY 12, 1919.

1,335,254.

Patented Mar. 30, 1920.  
2 SHEETS—SHEET 1.

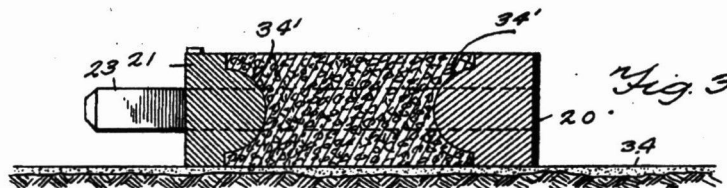
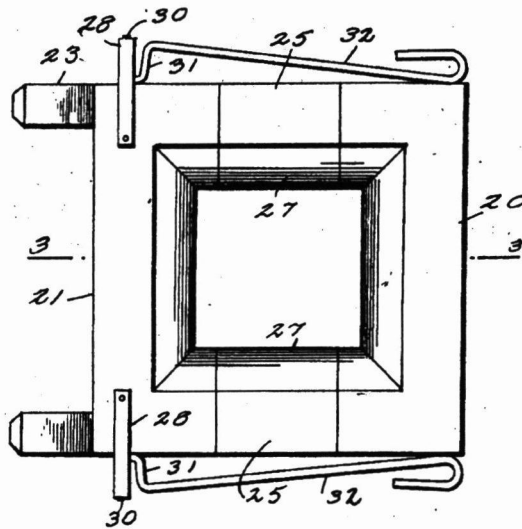
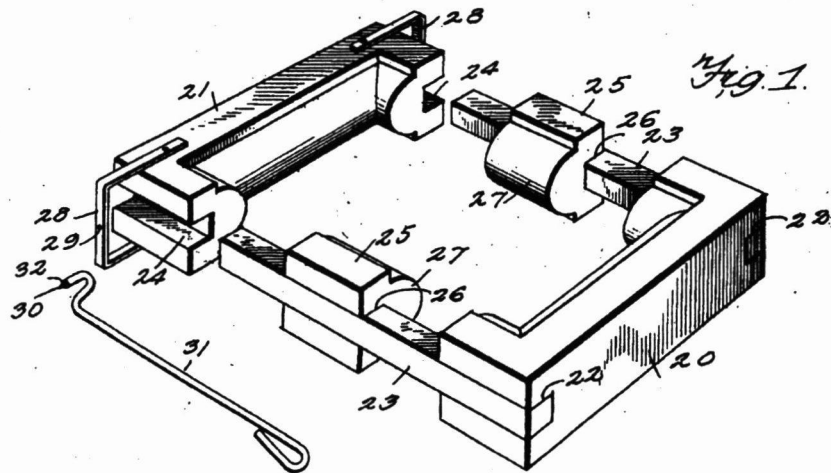

Inventor  
William E. Nelson,

W. E. NELSON.  
MOLDING APPARATUS.  
APPLICATION FILED MAY 12, 1919.

1,335,254.

Patented Mar. 30, 1920.  
2 SHEETS—SHEET 2.

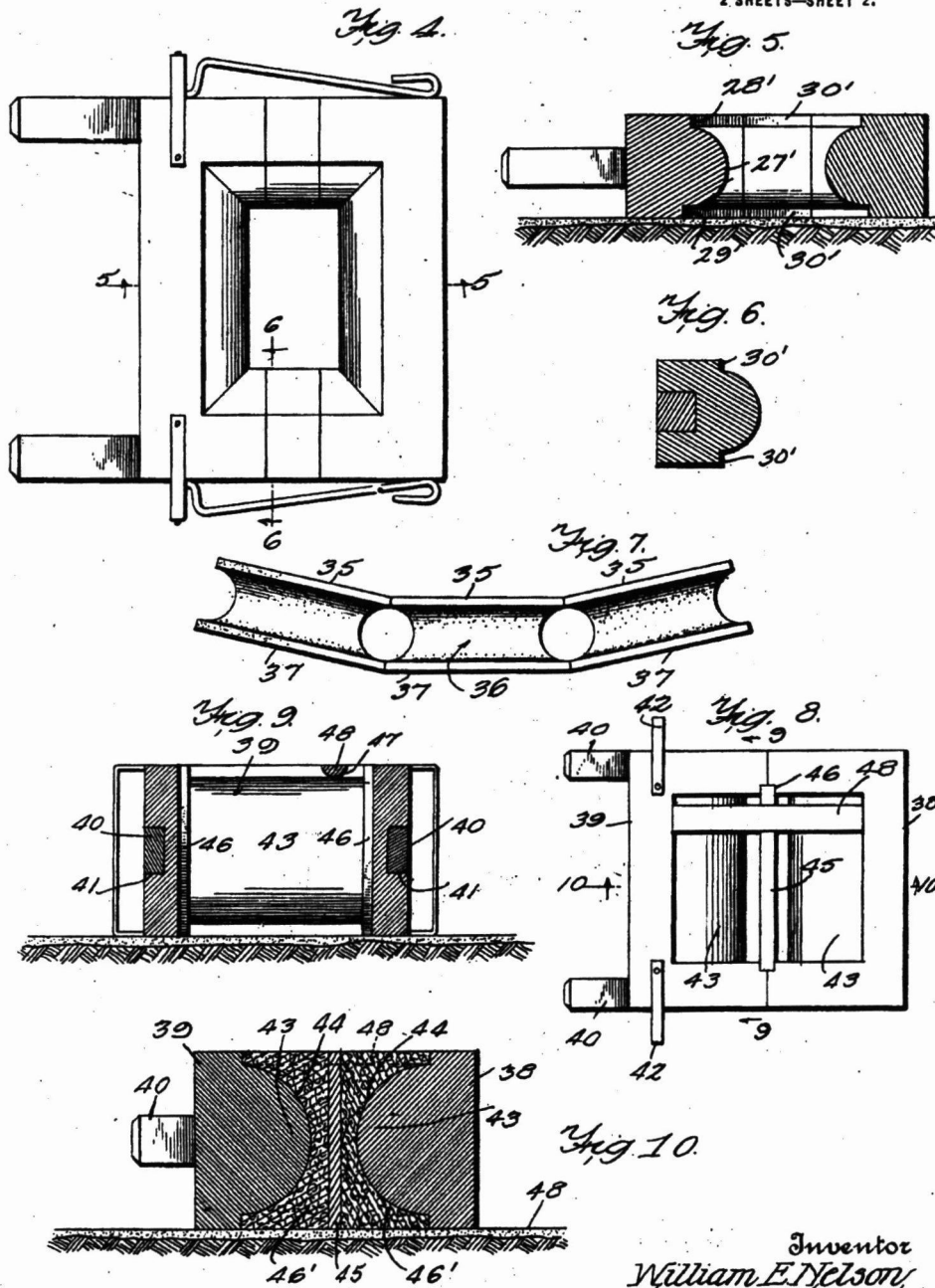

Inventor  
William E. Nelson

C. L. Parker  
Attorney

NATIONAL REGISTER OF HISTORIC PLACES  
CONTINUATION SHEET

The Plaza Hotel  
Grundy County, Missouri

Section number 9

Page 20

# UNITED STATES PATENT OFFICE.

WILLIAM E. NELSON, OF SAN ANTONIO, TEXAS.

TRADE-MARK FOR CONCRETE BUILDING-BLOCKS

ACT OF FEBRUARY 20, 1904.

142,638.

Registered May 17, 1921.

Application filed November 1, 1920. Serial No. 122,042.

## STATEMENT.

To all whom it may concern:

Be it known that I, WILLIAM E. NELSON, a citizen of the United States of America, residing at San Antonio, in the county of Bexar, State of Texas, and doing business in the Hicks Building, in said city, have adopted and used the trade-mark shown in the accompanying drawing, for concrete

building-blocks, in Class No. 12, Construction materials.

The trade-mark has been continuously used in my business since February 1, 1920.

The trade-mark is applied directly to the goods by impressing the same thereon.

WILLIAM E. NELSON.



## DECLARATION.

State of Texas, county of Harris, ss:

WILLIAM E. NELSON, being duly sworn, deposes and says that he is the applicant named in the foregoing statement; that he believes the foregoing statement is true; that he believes himself to be the owner of the trade-mark sought to be registered; that no other person, firm, corporation, or association, to the best of his knowledge and belief, has the right to use said trade-mark in the United States, either in the identical form or in any such near resemblance thereto as might be calculated to deceive; that

said trade-mark is used by him in commerce among the several States of the United States; that the description and drawing presented truly represent the trade-mark sought to be registered; and that the facsimiles show the trade-mark as actually used upon the goods.

WILLIAM E. NELSON.

Subscribed and sworn to before me, a notary public, this 18th day of October, 1920.

[L.S.] MAUDE M. DE FRENSE,  
Notary Public.

NATIONAL REGISTER OF HISTORIC PLACES  
CONTINUATION SHEET

The Plaza Hotel  
Grundy County, Missouri

Section number 9

Page 21

---

**Selected Bibliography**

Billig, Kurt, *Precast Concrete*, (New York, NY, D. Van Nostrand Co., 1955.

\_\_\_\_\_. *Structural Concrete*. London: Macmillan & Co. Ltd., 1960.

Childe, H. L. *Concrete Products and Cast Stone*. London: Concrete Publications, Ltd,  
1949.

“Concrete Housing in England,” *Concrete* 31 (August 1927), 28.

Condit, Carl W. *American Building Art: The Twentieth Century*. New York: Oxford  
University Press, 1961.

Denslow, William Ray. *Centennial History of Grundy County, Missouri 1839-1939*.  
Trenton: W. R. Denslow, 1939.

Ey, Victor. “Distinctive Block Made With Own Design of Equipment.” *Concrete* 32  
(February 1928), 35-38.

\_\_\_\_\_. *Concrete* 34 (June 1929), 20-21.

*Mid-West Contractor*, August 14, 1929, 32; October 16, 1929, 32.

Nelson, William E. “Molding Apparatus.” Patent No. 1,335,254, March 30, 1920. United  
States Patent Office, Washington, D.C.

\_\_\_\_\_. “Trade-Mark for Concrete Building-Blocks.” Register No. 142,638, May 17,  
1921. United States Patent Office, Washington, D.C.

Porter, Tom. Letter to C. Millstein, September 7, 2000.

NATIONAL REGISTER OF HISTORIC PLACES  
CONTINUATION SHEET

The Plaza Hotel  
Grundy County, Missouri

Section number 9

Page 22

---

Raafat, Aly Ahmed, *Reinforced Concrete In Architecture*. New York: Reinhold Publishing Corporation, 1958.

Secretary of State, Jefferson City, Missouri. Articles of Incorporation for Nelstone Company, Carthage, Missouri, No. X00005060 and E. S. Rhodes, Kansas City, Missouri, No. 00043589, July 22, 1929.

*Time Was* 6 (Spring 1982), 38-39. Copy located at the Grundy County Library, Trenton, Missouri.

*Trenton (Missouri) Republican-Times*. Various dates from June 1929-June 1930.

*Western Contractor*. June 26, 1929, 26, 34; July 10, 1929, 30, August 7, 1929, 30.

**10. Geographical Data**

**Acreeage of Property** less than one acre

**UTM References**

A. Zone	Easting	Northing	B. Zone	Easting	Northing
15	447230	4435950			
C. Zone	Easting	Northing	D. Zone	Easting	Northing

[ ] See continuation sheet

**Verbal Boundary Description**

(Describe the boundaries of the property on a continuation sheet.)

**Boundary Justification**

(Explain why the boundaries were selected on a continuation sheet.)

**11. Form Prepared By**

name/title Cydney E. Millstein

organization Architectural and Historical Research date September 26, 2000

street & number P.O. Box 22551 telephone 816/363-0567

city or town Kansas City state MO zip code 64113

**Additional Documentation**

Submit the following items with the completed form:

**Continuation Sheets**

**Maps**

A **USGS map** (7.5 or 15 minute series) indicating the property's location.

A **Sketch map** for historic districts and properties having large acreage or numerous resources.

**Photographs**

Representative **black and white photographs** of the property.

**Additional Items**

(Check with the SHPO or FPO for any additional items)

**Property Owner**

(Complete this item at the request of SHPO or FPO.)

name Wendell Lenhart

street & number Plaza Apartments L.L.C. telephone 660/359-2212

city or town Trenton state MO zip code 64683

NATIONAL REGISTER OF HISTORIC PLACES  
CONTINUATION SHEET

The Plaza Hotel  
Grundy County, Missouri

Section number 10 Page 23

---

**Verbal Boundary Description**

All of lots 5 and 6 and all of the northeasterly 22 feet 2 inches of Lot 4, together with the vacated southeasterly 8 1/3 feet of alley adjoining; also all of Lot 7 except the southeasterly 6 1/3 feet thereof, all in Block 4 in the original survey of the town or city of Trenton, Grundy County, Missouri, except for alleyways, both existing and vacated.

**Boundary Justification**

The nominated property includes the entire parcel historically associated with the Plaza Hotel.

UNITED STATES DEPARTMENT OF THE INTERIOR  
NATIONAL PARK SERVICE

To: APP

NATIONAL REGISTER OF HISTORIC PLACES  
EVALUATION/RETURN SHEET

REQUESTED ACTION: NOMINATION

PROPERTY Plaza Hotel  
NAME:

RECEIVED

MAR 01 2001

MULTIPLE  
NAME:

HISTORIC PRESERVATION  
PROGRAM

STATE & COUNTY: MISSOURI, Grundy

DATE RECEIVED: 12/29/00      DATE OF PENDING LIST: 1/10/01  
DATE OF 16TH DAY: 1/26/01      DATE OF 45TH DAY: 2/12/01  
DATE OF WEEKLY LIST:

REFERENCE NUMBER: 01000010

REASONS FOR REVIEW:

APPEAL: N    DATA PROBLEM: N    LANDSCAPE: N    LESS THAN 50 YEARS: N  
OTHER: N    PDIL: N    PERIOD: N    PROGRAM UNAPPROVED: N  
REQUEST: N    SAMPLE: N    SLR DRAFT: Y    NATIONAL: N

COMMENT WAIVER: N

ACCEPT     RETURN     REJECT    \_\_\_\_\_ DATE

ABSTRACT/SUMMARY COMMENTS:

RECOM./CRITERIA Return

REVIEWER Bohnd

DISCIPLINE Historic

TELEPHONE \_\_\_\_\_

DATE 2/8/01

DOCUMENTATION see attached comments (Y/N) see attached SLR Y/N

Plaza Hotel  
Grundy County, Missouri

National Register Comments:

The Plaza Hotel, in Trenton, Missouri, appears to meet National Register Criterion C in the areas of architecture and engineering. The hotel retains sufficient integrity to embody and reflect its local significance as an uncommon rural example of the Art Deco style in this region of the state, as well as the only example in the community; and also as an example of an innovative, unusual, and effective construction technique.

However, the loss of the portion of the building housing the theater, ballroom, and other spaces has resulted in a severe loss of integrity under Criterion A. The hotel no longer possesses the integrity of design, materials, workmanship, feeling, and association needed for the hotel to adequately embody and convey its former associative significance as a first class hotel and a major gathering place for social and commercial events under National Register criteria.

Once the nomination's blanks and statement of significance have been revised to drop claims of eligibility under Criterion A, the National Register will be happy to review it again.

STATE OF MISSOURI  
DEPARTMENT OF NATURAL RESOURCES

Roger B. Wilson

XXXXXXXXXXXX  
Mel Carnahan, Governor • Stephen M. Mahfood, Director

DIVISION OF STATE PARKS

P.O. Box 176 Jefferson City, 65102-0176 (573) 751-2479

FAX (573) 751-8656

December 5, 2000

Ms. Carol Shull  
United States Department of the Interior  
National Park Service  
National Register of Historic Places  
Mail Stop 2280, Suite 400  
1849 C Street, NW  
Washington, D. C. 20240

Dear Ms. Shull:

Enclosed please find the following two nominations to the National Register of Historic Places and additional documentation for a previously listed property:

The Plaza Hotel  
Grundy County, MO

Tromanhauser, Norman, House  
Jackson County, MO

Townley Metal & Hardware Company Building (additional documentation)  
Jackson County, MO

The nominations for the Plaza Hotel and the Norman Tromanhauser were approved by our state review board, the Missouri Advisory Council on Historic Preservation, on November 3, 2000. Additional documentation for the Townley Metal & Hardware Company Building (listed April 14, 1994) was approved by our state review board on August 11, 2000. All owners and appropriate elected public officials were notified and provided at least thirty (30) days to comment on the above proposed nominations and the additional documentation in accordance with 36CFR60.6, interim regulations, using the exact notification format recommended by the National Register. No objections, notarized or otherwise, were received on the above referenced actions.

The City of Kansas City, as part of its responsibilities as a Certified Local Government, reviewed the proposed nomination of the Tromanhauser House and the additional documentation for the Townley Metal & Hardware Company Building prior to their presentation to the state review board. Enclosed you will find letters of support from both the Mayor of Kansas City, the chief elected official, and the Landmarks Commission.

If you have any questions concerning this submission, please contact Steven Mitchell of my staff at 573/751-4692.

Sincerely,

HISTORIC PRESERVATION PROGRAM

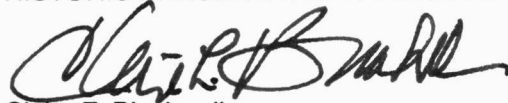

Claire F. Blackwell  
Director and Deputy State Historic  
Preservation Officer

CFB:sem

Enclosure: as stated

UNITED STATES DEPARTMENT OF THE INTERIOR  
NATIONAL PARK SERVICE

NATIONAL REGISTER OF HISTORIC PLACES  
EVALUATION/RETURN SHEET

REQUESTED ACTION: RESUBMISSION

NAME: Plaza Hotel

MULTIPLE  
NAME:

STATE & COUNTY: MISSOURI, Grundy

DATE RECEIVED: 06/12/01      DATE OF PENDING LIST:  
DATE OF 16TH DAY:                      DATE OF 45TH DAY: 7/27/01  
DATE OF WEEKLY LIST:

REFERENCE NUMBER: 01000010

NOMINATOR: STATE

DETAILED EVALUATION: Y

     ACCEPT           RETURN           REJECT                           DATE

ABSTRACT/SUMMARY COMMENTS:

RECOM. / CRITERIA Accept - A+C  
REVIEWER Poland                      DISCIPLINE Historia  
TELEPHONE \_\_\_\_\_                      DATE 7/18/01  
DOCUMENTATION see attached comments Y/N see attached SLR Y/N

STATE OF MISSOURI  
DEPARTMENT OF NATURAL RESOURCES  
DIVISION OF STATE PARKS  
P.O. Box 176 Jefferson City, 65102-0176 (573) 751-2479  
FAX (573) 751-8656

Bob Holden, Governor • Stephen M. Mahfood, Director

May 25, 2001

Ms. Carol Shull  
United States Department of the Interior  
National Park Service  
National Register of Historic Places  
Mail Stop 2280, Suite 400  
1849 C Street, NW  
Washington, D. C. 20240

Dear Ms. Shull:

Enclosed please find the following resubmitted nomination:

The Plaza Hotel  
Grundy County, MO

The nomination for the Plaza Hotel was approved by our state review board, the Missouri Advisory Council on Historic Preservation, on November 3, 2000. All owners and appropriate elected public officials were notified and provided at least thirty (30) days to comment on the above proposed nomination in accordance with 36CFR60.6, interim regulations, using the exact notification format recommended by the National Register. No objections, notarized or otherwise, were received on the above referenced actions.

The nomination was originally received by the National Register on December 29, 2000, and was returned to our program on March 1, 2001, for the reasons given on the enclosed evaluation/return sheet. The reasons for the return were not discussed with our staff until the return had been received. Our staff contends that the original documentation was sufficient to justify both significance and integrity and that the concerns expressed by the reviewer could have been easily addressed without the necessity for a return, if our staff had only been consulted during the review process.

Regarding the reviewer's concerns, the nomination preparer has attempted to clarify the information contained in the original nomination (on page 2) with an additional paragraph on a revised page 3. We request that, before any action is taken on this resubmitted nomination, the Register staff contact our staff. We also request that review of this resubmitted nomination be expedited. If you have any questions concerning this submission, please contact Steven Mitchell of my staff at 573/751-4692.

Sincerely,

HISTORIC PRESERVATION PROGRAM

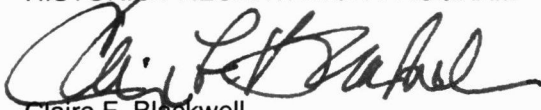

Claire F. Blackwell  
Director and Deputy State Historic  
Preservation Officer

CFB:sem

Enclosure: as stated

c: Jackie Soptic  
Cydney Millstein



P  
COLD

HOT

'97 10 14

The Plaza Hotel

Grundy County, Missouri

Nancy Sundehn

10/14/97

NES Consultants

Box 43 St. Joseph, Mo

Main + 8th St. facades looking NW

#1



The Plaza Hotel

Grundy County, Missouri

Nancy Sandehn

10/14/97

NES Consultants

Box 43, St. Joseph, Mo

detail of hotel lobby entrance - looking NW

#2

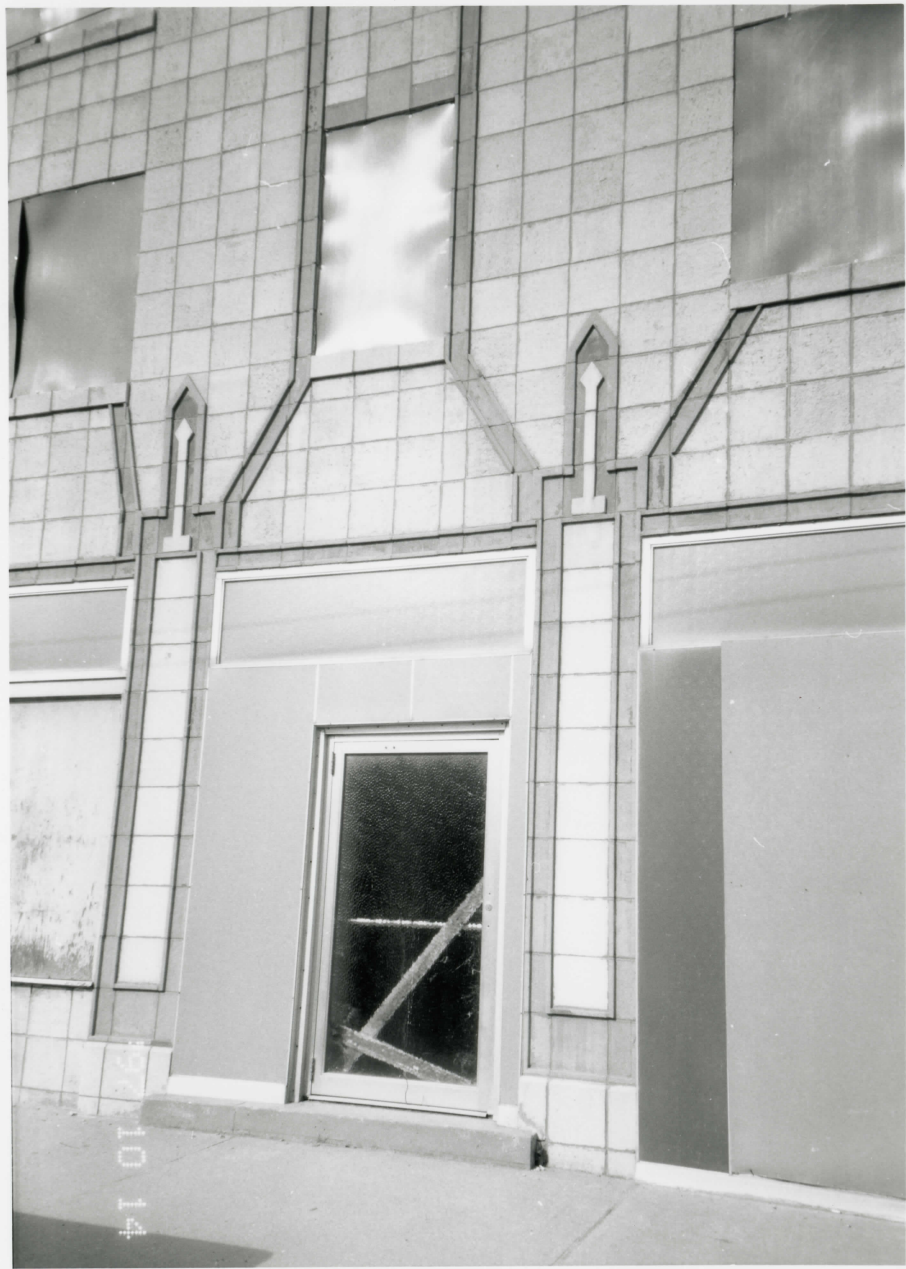

1921 10 14

The Plaza Hotel

Grundy County Missouri

Nancy Sandehn

10/14/97

NES Consultants

Box 43, St. Joseph, Mo

detail - Entrance on Main to lower level

looking NW

#3



The Plaza Hotel  
Grundy County, Missouri  
Nancy Sandehn

10/14/97

NES Consultants

Box 43, St. Joseph, Mo

detail - Plaza sign looking NE

#4



The Plaza Hotel

Grundy County, Missouri

Nancy Sandehn

10/14/97

NES Consultants

Box 13 St Joseph, MO

8th St. facade looking SW

#5



'97 10 14

The Plaza Hotel  
Grundy County, Missouri

Nancy Sandehn

10/14/97

NES Consultants

Box 43, St. Joseph, Mo

rear facades of theatre and hotel - looking E

#6



'97 10 14

The Plaza Hotel  
Grandy County, Missouri  
Nancy Sandehn

10/14/97

NES Consultants  
Box 43 St Joseph, MO

detail - lower level entrance looking N.W

#7



'97 10 14

The Plaza Hotel  
Grundy County, Missouri

Nancy Sandehs

10/14/97

NES Consultants

Box 43 St. Joseph, Mo

detail - wall murals in theater - looking N

#8



'97 10 14

The Plaza Hotel

Grandy County, Missouri

Nancy Sandehn

10/14/97

NES Consultants

Box 43, St. Joseph, Mo

Proscenium arch, Plaza Theater looking NE

#9



EXIT

'97 10 14

The Plaza Hotel

Grandy County, Missouri

Nancy Sandelin

10/14/97

NES Consultants

Box 43, St. Joseph, Mo

view in ballroom / lower level theater looking E

#10



The Plaza Hotel

Grundy County, Missouri

Nancy Sandehn

10/14/97

NES Consultants

Box 43, St. Joseph, Mo

Hotel Coffee Shop, looking N

# 11



The Plaza Hotel  
Grundy County, Missouri  
Nancy Sandehn

10/14/97

NES Consultants  
Box #3 St. Joseph, Mo  
Hotel Lobby looking N

#12



The Plaza Hotel  
Grandy County, Missouri  
Nancy Sandehn

10/14/97

NES Consultants

Box 43, St. Joseph, Mo

Hotel Lobby, looking NE

#13



The Plaza Hotel

Grundy County, MO

Cydney Millstein

September 2000

Architectural and Historical Research, P.O. Box 22551,  
Kansas City, MO

East and north elevations

#14 new looking southwest

September 2000

Cydney Millstein photographer



The Plaza Hotel

#2

Grandy County, MO

Cydney Millstein

September 2000

Architectural and Historical Research, P.O. Box  
22551

Looking north northwest

#15

September 2000

Cydney Millstein, photographer



The Plaza Hotel

#3

Grundy County, MO

Cyndee Millstein

September 2000

Architectural and Historical Research, Plaza, 22551,  
McKanas City, mo

Looking Northwest West

# 16

September 2000

Cyndee Millstein, photographer

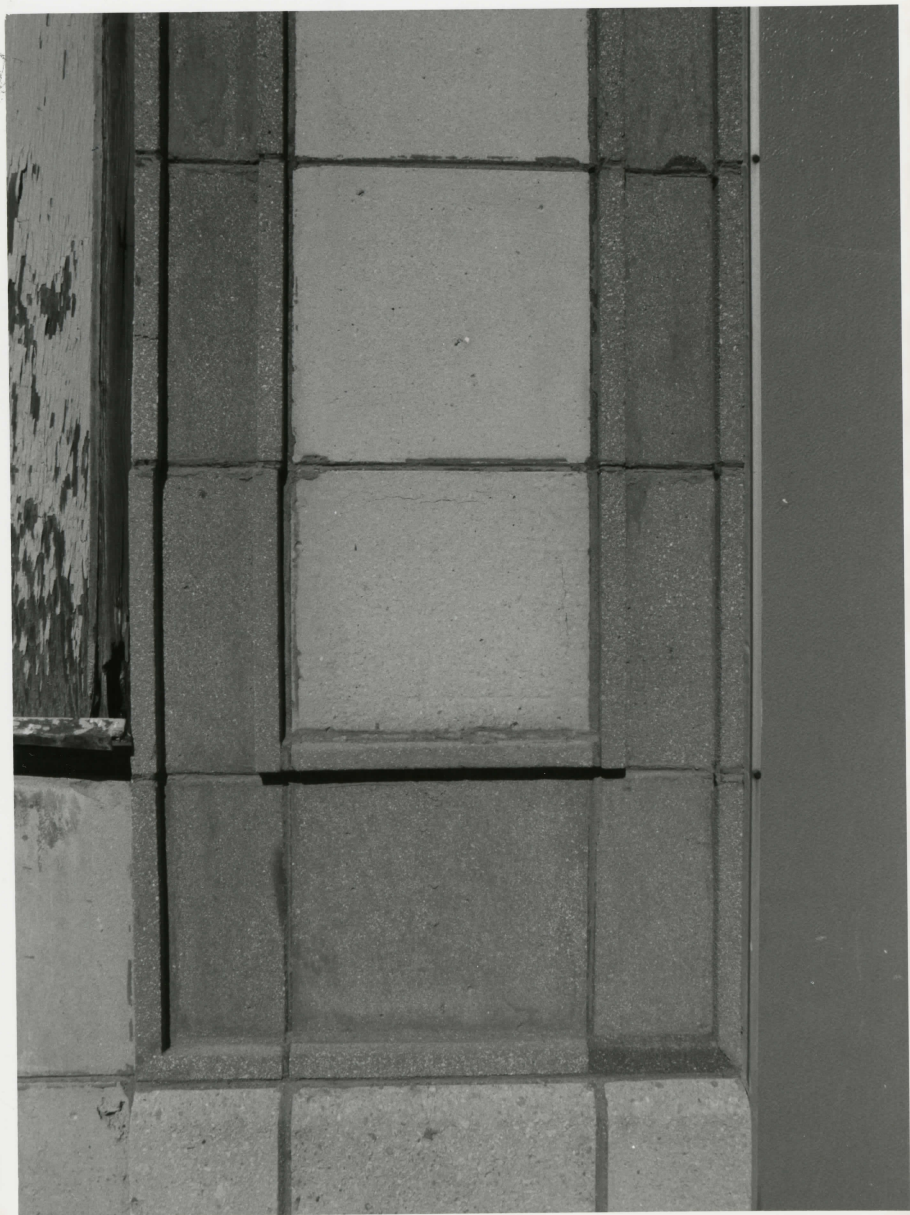

The Plaza Hotel

#7

Grundy County, Mo

Cyndney Millstein

September 2000

Architectural and Historical Research, P. O. Box 22551  
Kansas City, Mo

detail of Nelstone, looking northwest

#117 view facing west

Cyndney Millstein, photographer



The Plaza Hotel

Grundy County, MO

Sydney Millstein

September 2000

Architectural and Historical Research, P.O. Box 22551

South Kansas City, MO

looking north/northwest showing demolished  
theater

#18

Sydney Millstein, photographer



The Plaza Hotel

#6

Grundy County, MO

Cydney Millstein

September 2007

Architectural and Historical Research, P.O. Box 22551,

Kansas City, MO

lobby stairs, 1st floor, looking NW

#19

view facing Northwest

Cydney Millstein, photographer



The Plaza Hotel

#7

Grundy County, Mo

Cydney Millstein

September 2000

Architectural and Historical Research, P.O. Box 22551

Kansas City, Mo

main corridor, 5th floor, facing W

#20

Cydney Millstein, photographer

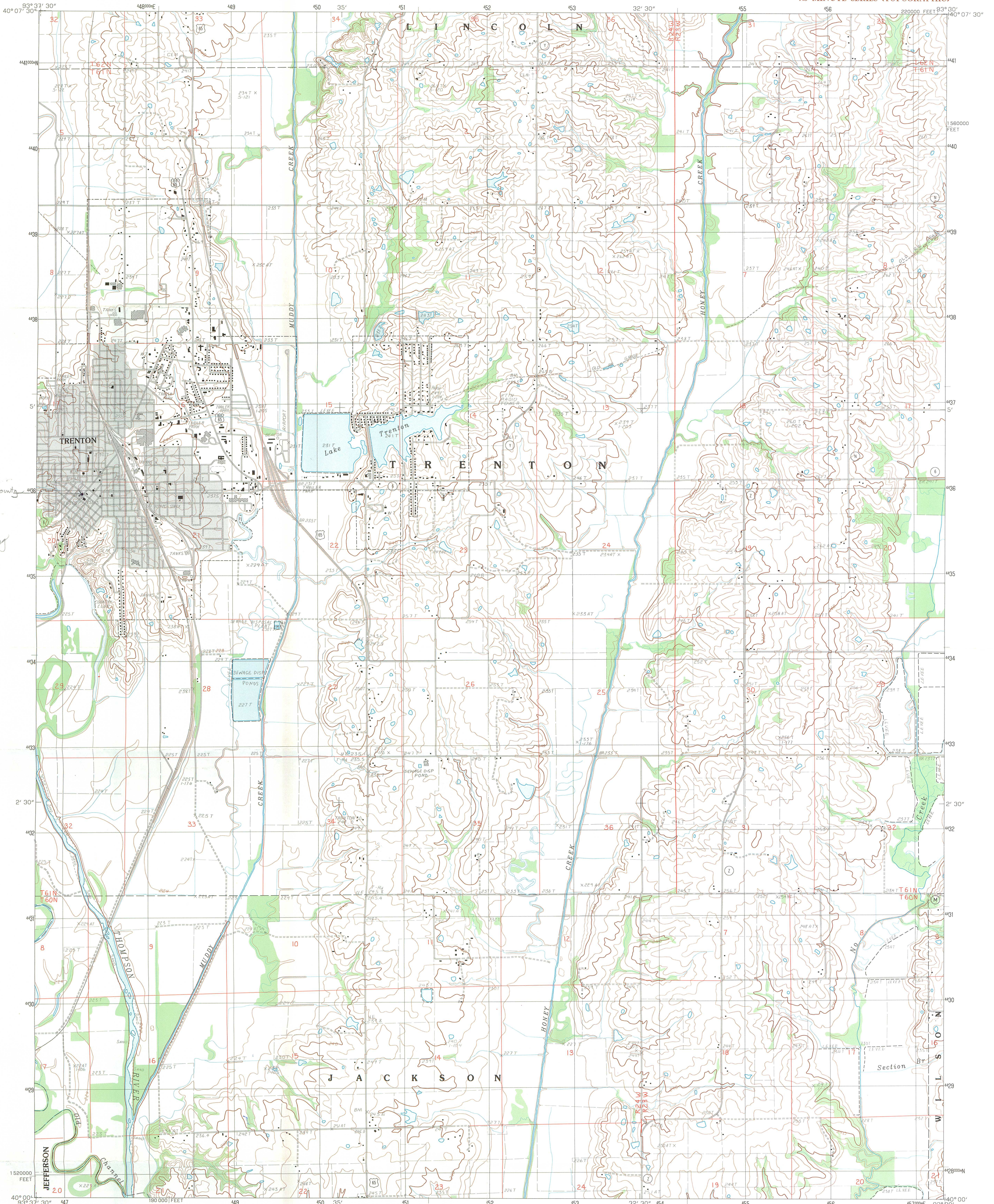

Plaza Hotel  
Trenton, Grundy County  
Moscow  
Zone 15  
447230 Easting  
4435950 Northing

PRODUCED BY THE UNITED STATES GEOLOGICAL SURVEY CONTROL BY: . . . . . USGS AND NOS/NOAA COMPILED FROM AERIAL PHOTOGRAPHS TAKEN . . . . . 1981 FIELD CHECKED . . . . . MAP EDITED . . . . . 1984 PROJECTION . . . . . UNIVERSAL TRANSVERSE MERCATOR GRID 1000-METER UNIVERSAL TRANSVERSE MERCATOR 1000-FOOT STATE GRID TICS . . . . . MISSOURI, CENTRAL ZONE 1584 MAGNETIC NORTH DECLINATION . . . . . 5'00" EAST VERTICAL DATUM . . . . . NATIONAL GEODETIC VERTICAL DATUM OF 1929 HORIZONTAL DATUM . . . . . 1927 NORTH AMERICAN DATUM To place on the predicted North American Datum of 1983, move the projection lines as shown by dashed corner ticks (2 meters north and 18 meters east) There may be private inholdings within the boundaries of any Federal and State Reservations shown on this map No distinction made between houses, barns, and other buildings Gray tint indicates area in which selected buildings are shown

PROVISIONAL MAP  
Produced from original  
manuscript drawings. Information  
shown as of date of  
photography. 1

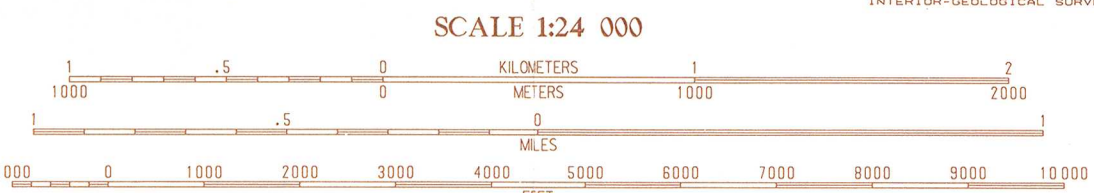

CONTOUR INTERVAL 4 METERS  
CONTROL AND FIELD ESTABLISHED ELEVATIONS SHOWN TO THE NEAREST 0.1 METER  
OTHER ELEVATIONS SHOWN TO THE NEAREST METER  
To convert meters to feet multiply by 3.2808  
To convert feet to meters multiply by .3048



1	2	3	1 Brinson
2	3	4	2 Spickard
3	4	5	3 Trenton West
4	5	6	4 Laredo
5	6	7	5 Shearwood
6	7	8	6 Farmersville
7	8		7 Chula
8			

CONTOURS AND ELEVATIONS IN METERS  
ROAD LEGEND

Improved Road  
Unimproved Road  
Trail  
Interstate Route U.S. Route State Route

THIS MAP COMPLIES WITH NATIONAL MAP ACCURACY STANDARDS FOR SALE BY U.S. GEOLOGICAL SURVEY, DENVER, COLORADO 80225, OR RESTON, VIRGINIA 22092 AND DIVISION OF GEOLOGY AND LAND SURVEY MISSOURI DEPARTMENT OF NATURAL RESOURCES, ROLLA, MISSOURI 65401

TRENTON EAST, MISSOURI  
PROVISIONAL EDITION 1984

4093-A5-TM-024